



**TEMPERATURE MEASUREMENT
SYSTEMS**

CATALOG 2013

**1502 ROYALL BLVD. • MALAKOFF, TX 75148
PHONE (903) 489-1405
FAX (903) 489-1794
www.tempmeassystems.com**



TABLE OF CONTENTS

SECTION 1 – THERMOCOUPLE

THERMOCOUPLE ASSEMBLY	
ORDERING INFORMATION	1
Thermocouple Elements:	
Bare Lead Thermocouples.....	2
With Extension Leads.....	3
With Armored Extension Leads.....	4
With Double Threaded Fixed Fittings.....	5
With Double Threaded Spring Loaded Fitting.....	6
With Fixed Threaded Fitting.....	7
With Spring Loading Hardware.....	8
With Extension Lead and Male Plug.....	9
With Armored Extension Lead and Male Plug.....	10
With Male Plug.....	11
Beaded Thermocouples.....	12
Noble Metal Thermocouples.....	12
Engine Type.....	13
Tubeskins Thermocouple Assemblies.....	14
Multipoint Thermocouple Assemblies.....	16
Thermocouple Data.....	16-18

SECTION 2 – RTD's

RTD ASSEMBLY ORDERING INFORMATION	1
RTD Elements:	
Basic RTD.....	2
With Extended Leads.....	3
With Armored Extended Leads.....	4
With Double Threaded Fixed Fittings.....	5
With Double Threaded Spring Loaded Fitting.....	6
With Fixed Threaded Fitting.....	7
With Spring Loading Hardware.....	8
RTD Technical Data.....	9-13

SECTION 3 – TERMINAL HEADS, BLOCKS and EXTENSIONS

Terminal Heads:	
Aluminum/Cast Iron.....	1
Small Cast Aluminum.....	1
Stainless Steel.....	1
Screw Cover Polypropylene.....	2
Hinged Cover Polypropylene and Aluminum.....	2
Explosion Proof.....	2
Explosion Proof – Certified.....	3
Terminal Blocks:	
Ceramic Terminal Blocks.....	4
Barrier Blocks.....	4
Barrier Blocks Sectional.....	4
Oval Terminal Blocks.....	5
Mini Round Terminal Blocks.....	5
Round Ceramic Terminal Blocks.....	5
Extensions:	
Nipple Assemblies.....	6
Nipple-Union Assemblies.....	6
Nipple-Union-Nipple Assemblies.....	6

SECTION 4 – THERMOWELLS

Straight and Tapered Threaded.....	1
Barstock Thermowells.....	1
Metallic Protection Tubes: Plain, with Mounting Bushing and Flanged Connections.....	2
Socket Weld, Straight and Tapered.....	3
Weld-in Thermowells.....	3
Flanged Thermowells: Straight and Tapered.....	3
Flanged Tantalum Sleeve Thermowells.....	4
Van Stone Thermowells.....	4
Sample Probes.....	5
Large Bore Thermowells.....	5
Ceramic Protection Tubes: Plain, with Hex Nipple, with Standard Nipple.....	6
Threaded Bimetal Thermometer Wells.....	7
Flanged Wells for Bimetal Thermometers.....	8
Socket Weld Bimetal Thermometer Wells.....	8
Plugs and Chains.....	9
Material Codes.....	9
Material Specifications.....	10
Specialty Thermowells.....	11
Services: Coatings, Hard Facings, Testing and Calculations.....	11
Technical Data.....	12
Warranty.....	13

SECTION 5 – WIRE

Technical Information – Thermocouple Wire.....	1-4
Thermocouple Wire and Multipair Cable – Insulation Specifications.....	5-6
Standard Constructions.....	7-8
Extension Grade TC Wire-Standard Constructions.....	9-11
RTD Wire-Construction Characteristics.....	11
RTD Wire-Standard Constructions and Ordering Information.....	12

SECTION 6 – FITTINGS and HARDWARE

Compression Fittings – Carbon Steel and Stainless Steel.....	1
Cord Grip Connectors.....	1
Thermocouple Connectors – Standard and Miniature.....	2-3

SECTION 1

THERMOCOUPLES

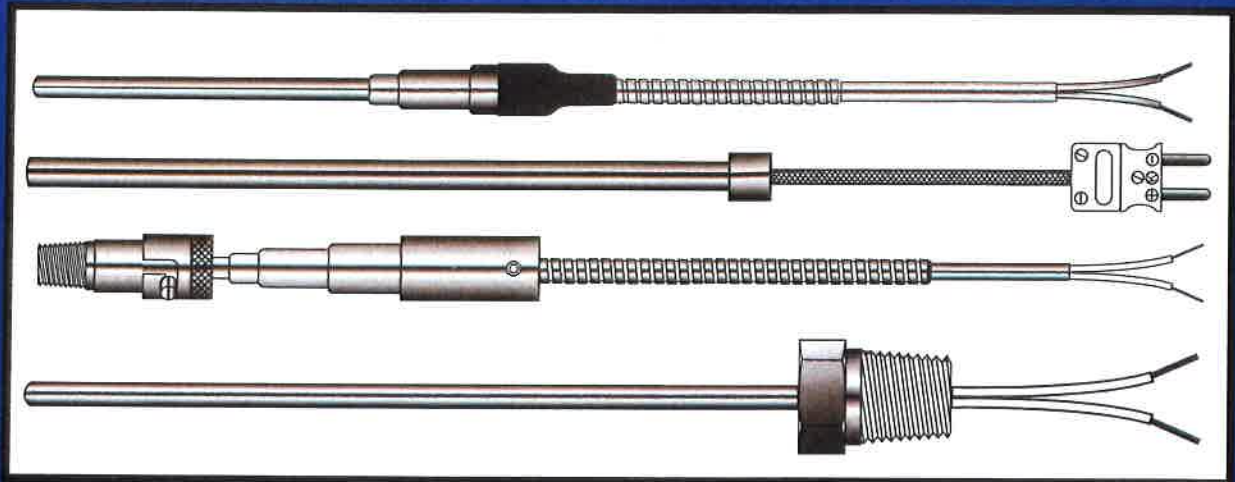

THERMOCOUPLE INDEX - SECTION 1

THERMOCOUPLE ASSEMBLY	
ORDERING INFORMATION	1
Thermocouple Elements:	
Bare Lead Thermocouples	2
With Extension Leads.....	3
With Armored Extension Leads.....	4
With Double Threaded Fixed Fittings	5
With Double Threaded Spring Loaded Fitting	6
With Fixed Threaded Fitting	7
With Spring Loading Hardware	8
With Extension Lead and Male Plug	9
With Armored Extension Lead and Male Plug	10
With Male Plug	11
Beaded Thermocouples	12
Noble Metal Thermocouples	12
Engine Type	13
 Tubeskins Thermocouple Assemblies	14
 Multipoint Thermocouple Assemblies	15
 Thermocouple Data	16-18

THERMOCOUPLE



Thermocouple Assemblies

ORDERING INFORMATION

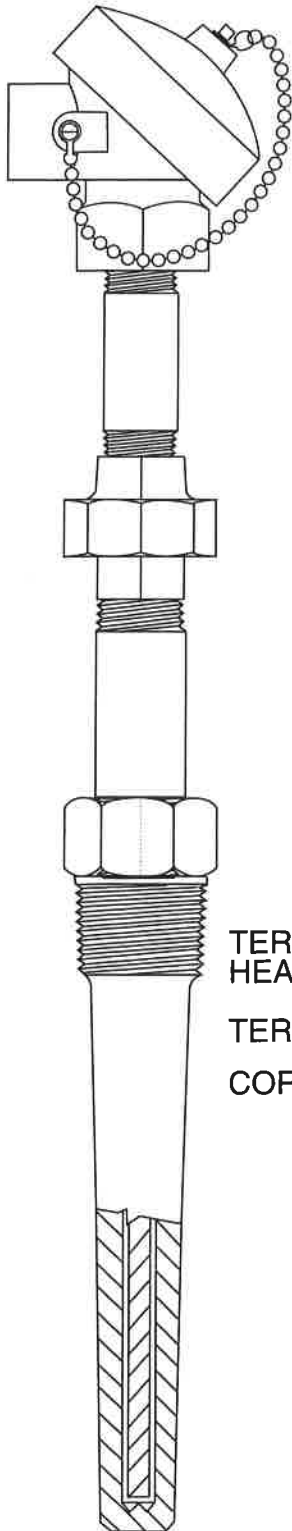

To specify thermocouple assembly, follow the steps shown below:

For Types 1, 4, S4, 6, and 10:

- Step 1 - Specify Terminal Head from Section 3.
- Step 2 - Specify Terminal Block from Section 3.
- Step 3 - Specify Extension Type (if required) from Section 3.
- Step 4 - Specify Thermocouple Element from Section 1.
- Step 5 - Specify Thermowell or Protection Tube from Section 4.

EXAMPLE:

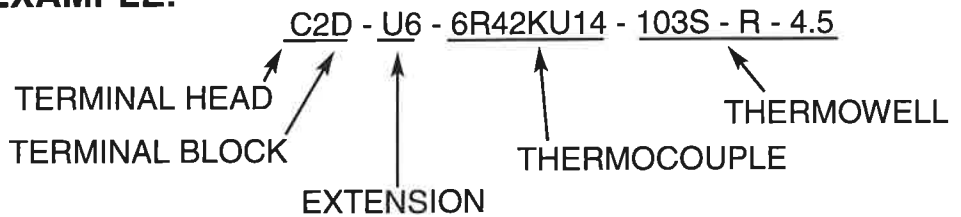

For Types 2, and 3:

- Step 1 - Specify Terminal Head from Section 3.
- Step 2 - Specify Terminal Block from Section 3.
- Step 3 - Specify Cord Grip Connector (if required) from Section 3.
- Step 4 - Specify Thermocouple Element from Section 1.
- Step 5 - Specify Compression Fitting (if required) from Section 6.
- Step 6 - Specify Thermowell or Protection Tube (if required) from Section 4.

EXAMPLE:

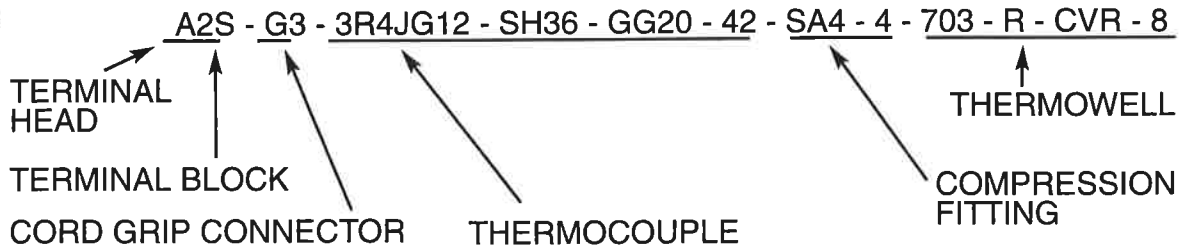

Junction Types

E - Exposed -Welded



G - Grounded



U - Ungrounded



P - Welding Pad



THERMOCOUPLE

TMS

Thermocouple Type 1

** Bare Lead MgO Insulated Thermocouple

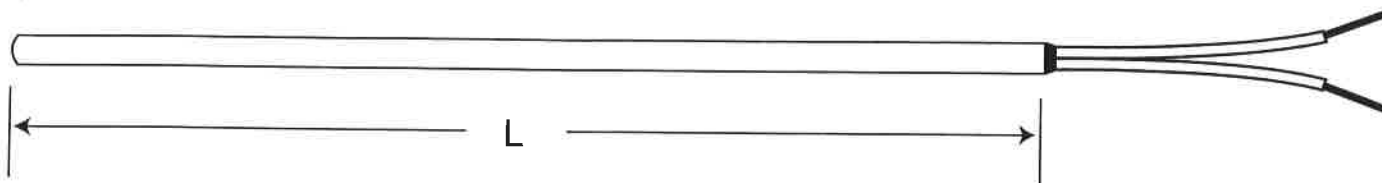

ORDERING INFORMATION:----- 1 - R - 6 - 2K - U - 24

DESIGN TYPE ←

SHEATH MATERIAL ←

- P - 304SS Q - 310SS
- R - 316SS X - OTHER(SPECIFY)
- J - INCONEL 600

SHEATH DIA. ←

- 1 - .062 (1/16") 4 - .250 (1/4")
- 2 - .125 (1/8") 5 - .313 (5/16")
- 3 - .188 (3/16") 6 - .375 (3/8")

THERMOCOUPLE CALIBRATION TYPE ←

- | | |
|-------------------------------|---|
| J - Single Iron/Constantan | R - Single Platinum/Platinum 13% Rhodium |
| 2J - Dual Iron/Constantan | 2R - Dual Platinum/Platinum 13% Rhodium |
| K - Single Chromel/Alumel | S - Single Platinum/Platinum 10% Rhodium |
| 2K - Dual Chromel/Alumel | 2S - Dual Platinum/Platinum 10% Rhodium |
| E - Single Chromel/Constantan | B - Single Platinum 30% Rhodium/Platinum 6% Rhodium |
| 2E - Dual Chromel/Constantan | C - Single (W5Re) Tungsten 5% Rhenium/(W26Re) |
| T - Single Copper/Constantan | Tungsten 26% Rhenium |
| 2T - Dual Copper/Constantan | |

HOT JUNCTION ←

- | | |
|---------------------------------|-------------------------------|
| G - Grounded | E - Exposed |
| U - Ungrounded | GP - Grounded With Weld Pad |
| UI - Ungrounded Isolated (Dual) | UP - Ungrounded With Weld Pad |

SHEATH "L" LENGTH (SPECIFY IN INCHES) ←

**Bare Color Coded Leads.

THERMOCOUPLE



Thermocouple Type 2

MgO Insulated Thermocouples With 20 AWG Extension Lead



ORDERING INFORMATION:----- 2 - R - 2 - 2E - U - 12 - PP - 20 - 24

DESIGN TYPE ←

SHEATH MATERIAL ←

- P - 304SS Q - 310SS
- R - 316SS X - OTHER(SPECIFY)
- J - INCONEL 600

SHEATH DIA. ←

- 1 - .062 (1/16") 4 - .250 (1/4")
- 2 - .125 (1/8") 5 - .313 (5/16")
- 3 - .188 (3/16") 6 - .375 (3/8")

THERMOCOUPLE CALIBRATION TYPE ←

- J - Single Iron/Constantan R - Single Platinum/Platinum 13% Rhodium
- 2J - Dual Iron/Constantan 2R - Dual Platinum/Platinum 13% Rhodium
- K - Single Chromel/Alumel S - Single Platinum/Platinum 10% Rhodium
- 2K - Dual Chromel/Alumel 2S - Dual Platinum/Platinum 10% Rhodium
- E - Single Chromel/Constantan B - Single Platinum 30% Rhodium/Platinum 6% Rhodium
- 2E - Dual Chromel/Constantan C - Single (W5Re) Tungsten 5% Rhenium/(W26Re)
- T - Single Copper/Constantan Tungsten 26% Rhenium
- 2T - Dual Copper/Constantan

HOT JUNCTION ←

- G - Grounded E - Exposed
- U - Ungrounded GP - Grounded With Weld Pad
- UI - Ungrounded Isolated (Dual) UP - Ungrounded With Weld Pad

SHEATH "L" LENGTH (SPECIFY IN INCHES) ←

LEAD INSULATION ←

- PP - PVC-Solid GGST - Fiberglass Stranded
- GG - Fiberglass-Solid PPSHD - PVC Shielded
- TT - Teflon-Solid PPSB - PVC W/SS Overbraid
- PPST - PVC-Stranded GGSB - Fiberglass W/SS Overbraid
- TTST - Teflon-Stranded X - Other-Specify

LEAD WIRE GAUGE - 20 AWG STANDARD ←

LEAD LENGTH IN INCHES ←

THERMOCOUPLE

TMS

Thermocouple Type 3

MgO Insulated Thermocouples With 20 AWG Armored Lead



ORDERING INFORMATION:----- 3 - J - 4 - K - U - 24 - TH - 36 - GG - 20 - 42

DESIGN TYPE ←

SHEATH MATERIAL ←

- P - 304SS
- R - 316SS
- J - INCONEL 600
- Q - 310SS
- X - OTHER(SPECIFY)

SHEATH DIA. ←

- 1 - .062 (1/16")
- 2 - .125 (1/8")
- 3 - .188 (3/16")
- 4 - .250 (1/4")
- 5 - .313 (5/16")
- 6 - .375 (3/8")

THERMOCOUPLE CALIBRATION TYPE ←

- J - Single Iron/Constantan
- 2J - Dual Iron/Constantan
- K - Single Chromel/Alumel
- 2K - Dual Chromel/Alumel
- E - Single Chromel/Constantan
- 2E - Dual Chromel/Constantan
- T - Single Copper/Constantan
- 2T - Dual Copper/Constantan
- R - Single Platinum/Platinum 13% Rhodium
- 2R - Dual Platinum/Platinum 13% Rhodium
- S - Single Platinum/Platinum 10% Rhodium
- 2S - Dual Platinum/Platinum 10% Rhodium
- B - Single Platinum 30% Rhodium/Platinum 6% Rhodium
- C - Single (W5Re) Tungsten 5% Rhenium/(W26Re) Tungsten 26% Rhenium

HOT JUNCTION ←

- G - Grounded
- U - Ungrounded
- UI - Ungrounded Isolated (Dual)
- E - Exposed
- GP - Grounded With Weld Pad
- UP - Ungrounded With Weld Pad

SHEATH "L" LENGTH (SPECIFY IN INCHES) ←

ARMOR ←

- SH - Stainless Steel
- PH - PVC Coated Galvanized
- PSH - PVC Coated Stainless Steel
- TH - Teflon Coated Stainless Steel

ARMOR LENGTH IN INCHES ←

LEAD INSULATION ←

- PP - PVC-Solid
- GG - Fiberglass-Solid
- TT - Teflon-Solid
- PPST - PVC-Stranded
- TTST - Teflon-Stranded
- GGST - Fiberglass Stranded
- PPSHD - PVC Shielded
- X - Other-Specify

LEAD WIRE GAUGE - 20 AWG STANDARD ←

LEAD LENGTH IN INCHES ←

THERMOCOUPLE



Thermocouple Type 4

MgO Insulated Thermocouple With Double Threaded Fixed Fitting

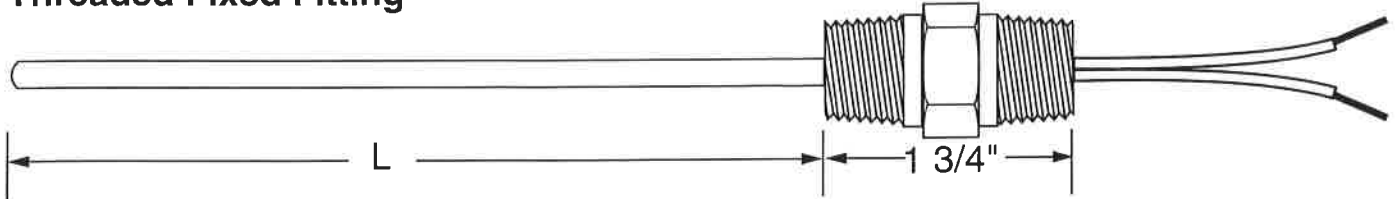

ORDERING INFORMATION:-----

4 - R - 6 - 2K - U - 24

DESIGN TYPE ←

SHEATH MATERIAL ←

- P - 304SS Q - 310SS
- R - 316SS X - OTHER(SPECIFY)
- J - INCONEL 600

SHEATH DIA. ←

- 1 - .062 (1/16") 4 - .250 (1/4")
- 2 - .125 (1/8") 5 - .313 (5/16")
- 3 - .188 (3/16") 6 - .375 (3/8")

THERMOCOUPLE CALIBRATION TYPE ←

- J - Single Iron/Constantan
- 2J - Dual Iron/Constantan
- K - Single Chromel/Alumel
- 2K - Dual Chromel/Alumel
- E - Single Chromel/Constantan
- 2E - Dual Chromel/Constantan
- T - Single Copper/Constantan
- 2T - Dual Copper/Constantan
- R - Single Platinum/Platinum 13% Rhodium
- 2R - Dual Platinum/Platinum 13% Rhodium
- S - Single Platinum/Platinum 10% Rhodium
- 2S - Dual Platinum/Platinum 10% Rhodium
- B - Single Platinum 30% Rhodium/Platinum 6% Rhodium
- C - Single (W5Re) Tungsten 5% Rhenium/(W26Re) Tungsten 26% Rhenium

HOT JUNCTION ←

- G - Grounded
- U - Ungrounded
- UI - Ungrounded Isolated (Dual)
- E - Exposed
- GP - Grounded With Weld Pad
- UP - Ungrounded With Weld Pad

SHEATH "L" LENGTH (SPECIFY IN INCHES) ←

**Bare Color Coded Leads Standard. 1/2" NPT Standard.
Fittings Are Available In Other Sizes - Consult TMS.

THERMOCOUPLE



Thermocouple Type 5

MgO Insulated Thermocouple With Fixed Fitting.

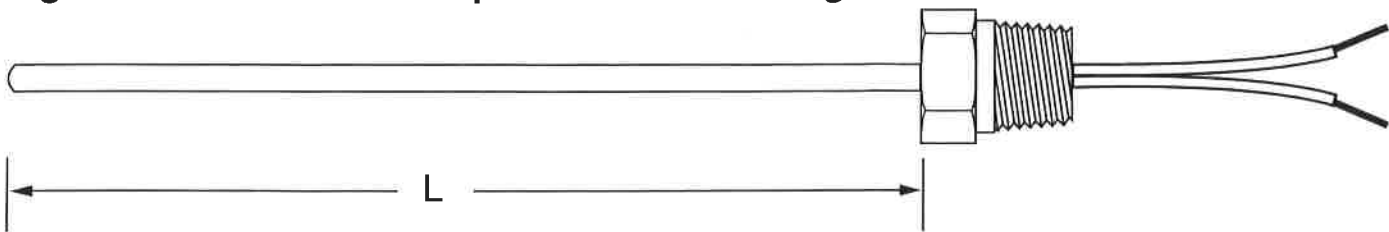

ORDERING INFORMATION:-----

5 - R - 4 - 2K - U - 24

DESIGN TYPE

SHEATH MATERIAL

- P - 304SS Q - 310SS
- R - 316SS X - OTHER(SPECIFY)
- J - INCONEL 600

SHEATH DIA.

- 1 - .062 (1/16") 4 - .250 (1/4")
- 2 - .125 (1/8") 5 - .313 (5/16")
- 3 - .188 (3/16") 6 - .375 (3/8")

THERMOCOUPLE CALIBRATION TYPE

- J - Single Iron/Constantan
- 2J - Dual Iron/Constantan
- K - Single Chromel/Alumel
- 2K - Dual Chromel/Alumel
- E - Single Chromel/Constantan
- 2E - Dual Chromel/Constantan
- T - Single Copper/Constantan
- 2T - Dual Copper/Constantan
- R - Single Platinum/Platinum 13% Rhodium
- 2R - Dual Platinum/Platinum 13% Rhodium
- S - Single Platinum/Platinum 10% Rhodium
- 2S - Dual Platinum/Platinum 10% Rhodium
- B - Single Platinum 30% Rhodium/Platinum 6% Rhodium
- C - Single (W5Re) Tungsten 5% Rhenium/(W26Re) Tungsten 26% Rhenium

HOT JUNCTION

- G - Grounded
- U - Ungrounded
- UI - Ungrounded Isolated (Dual)
- E - Exposed
- GP - Grounded With Weld Pad
- UP - Ungrounded With Weld Pad

SHEATH "L" LENGTH (SPECIFY IN INCHES)

1/2" NPT Standard.
Fittings Are Available In Other Sizes - Consult TMS.

THERMOCOUPLE



Thermocouple Type S4

MgO Insulated Thermocouple With Double Threaded Spring Load Bushing And Flexible Leads**

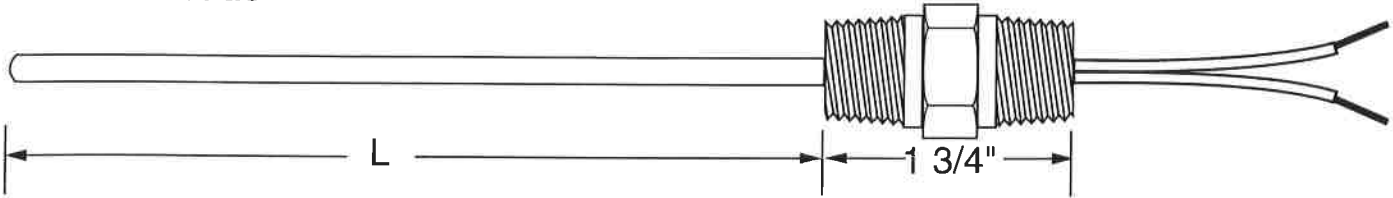

ORDERING INFORMATION:-----S4 - R - 6 - 2K - U - 24

DESIGN TYPE ←

SHEATH MATERIAL ←

- P - 304SS Q - 310SS
- R - 316SS X - OTHER(SPECIFY)
- J - INCONEL 600

SHEATH DIA. ←

- 1 - .062 (1/16") 4 - .250 (1/4")
- 2 - .125 (1/8") 5 - .313 (5/16")
- 3 - .188 (3/16") 6 - .375 (3/8")

THERMOCOUPLE CALIBRATION TYPE ←

- J - Single Iron/Constantan R - Single Platinum/Platinum 13% Rhodium
- 2J - Dual Iron/Constantan 2R - Dual Platinum/Platinum 13% Rhodium
- K - Single Chromel/Alumel S - Single Platinum/Platinum 10% Rhodium
- 2K - Dual Chromel/Alumel 2S - Dual Platinum/Platinum 10% Rhodium
- E - Single Chromel/Constantan B - Single Platinum 30% Rhodium/Platinum 6% Rhodium
- 2E - Dual Chromel/Constantan C - Single (W5Re) Tungsten 5% Rhenium/(W26Re)
- T - Single Copper/Constantan
- 2T - Dual Copper/Constantan

HOT JUNCTION ←

- G - Grounded E - Exposed
- U - Ungrounded GP - Grounded With Weld Pad
- UI - Ungrounded/Isolated (Dual) UP - Ungrounded With Weld Pad

SHEATH "L" LENGTH (SPECIFY) ←

**1/2" NPT Standard

Fittings Are Available In Other Sizes - Consult TMS.

THERMOCOUPLE



Thermocouple Type 6

****Spring Loaded MgO Insulated Thermocouple**

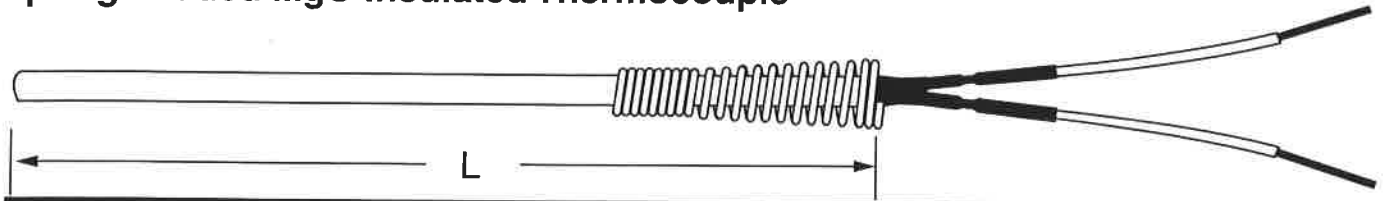

ORDERING INFORMATION:----- 6 - R - 4 - 2J - U - 18

DESIGN TYPE ←

SHEATH MATERIAL ←

- P - 304SS Q - 310SS
- R - 316SS X - OTHER(SPECIFY)
- J - INCONEL 600

SHEATH DIA. ←

- 1 - .062 (1/16") 4 - .250 (1/4")
- 2 - .125 (1/8") 5 - .313 (5/16")
- 3 - .188 (3/16") 6 - .375 (3/8")

THERMOCOUPLE CALIBRATION TYPE ←

- J - Single Iron/Constantan
- 2J - Dual Iron/Constantan
- K - Single Chromel/Alumel
- 2K - Dual Chromel/Alumel
- E - Single Chromel/Constantan
- 2E - Dual Chromel/Constantan
- T - Single Copper/Constantan
- 2T - Dual Copper/Constantan
- R - Single Platinum/Platinum 13% Rhodium
- 2R - Dual Platinum/Platinum 13% Rhodium
- S - Single Platinum/Platinum 10% Rhodium
- 2S - Dual Platinum/Platinum 10% Rhodium
- B - Single Platinum 30% Rhodium/Platinum 6% Rhodium
- C - Single (W5Re) Tungsten 5% Rhenium/(W26Re) Tungsten 26% Rhenium

HOT JUNCTION ←

- G - Grounded
- U - Ungrounded
- UI - Ungrounded Isolated (Dual)
- E - Exposed
- GP - Grounded With Weld Pad
- UP - Ungrounded With Weld Pad

SHEATH "L" LENGTH (SPECIFY IN INCHES) ←

**3" Flexible Leads Standard.

THERMOCOUPLE



Thermocouple Type 7

****MgO Insulated Thermocouples W/20 Gauge Extension Lead And Male Plug**

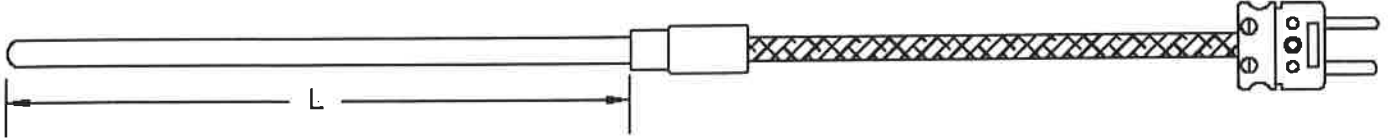

ORDERING INFORMATION:----- 7 - R - 4 - J - U - 12 - PP20-36

DESIGN TYPE ←

SHEATH MATERIAL ←

- P - 304SS Q - 310SS
- R - 316SS X - OTHER(SPECIFY)
- J - INCONEL 600

SHEATH DIA. ←

- 1 - .062 (1/16") 4 - .250 (1/4")
- 2 - .125 (1/8") 5 - .313 (5/16")
- 3 - .188 (3/16") 6 - .375 (3/8")

THERMOCOUPLE CALIBRATION TYPE ←

- J - Single Iron/Constantan R - Single Platinum/Platinum 13% Rhodium
- 2J - Dual Iron/Constantan 2R - Dual Platinum/Platinum 13% Rhodium
- K - Single Chromel/Alumel S - Single Platinum/Platinum 10% Rhodium
- 2K - Dual Chromel/Alumel 2S - Dual Platinum/Platinum 10% Rhodium
- E - Single Chromel/Constantan B - Single Platinum 30% Rhodium/Platinum 6% Rhodium
- 2E - Dual Chromel/Constantan C - Single (W5Re) Tungsten 5% Rhenium/(W26Re)
- T - Single Copper/Constantan
- 2T - Dual Copper/Constantan

HOT JUNCTION ←

- G - Grounded E - Exposed
- U - Ungrounded GP - Grounded With Weld Pad
- UI - Ungrounded Isolated (Dual) UP - Ungrounded With Weld Pad

SHEATH "L" LENGTH (SPECIFY IN INCHES) ←

LEAD INSULATION & LENGTH (INCHES) ←

- PP - PVC-Solid GGST - Fiberglass Stranded
- GG - Fiberglass-Solid PPSHD - PVC Shielded
- TT - Teflon-Solid PPSB - PVC W/SS Overbraid
- PPST - PVC-Stranded GGSB - Fiberglass W/SS Overbraid
- TTST - Teflon-Stranded X - Other-Specify

**Provided With Standard Size Connectors Unless Otherwise Specified.
 ***If Mating Female Jack Is Required, Add "FJ" After Complete Part Number.
EX: 7R42KU12-PP20-36-FJ.

THERMOCOUPLE



Thermocouple Type 8

****MgO Insulated Thermocouples With Armored 20 Gauge Extension Lead And Male Plug**

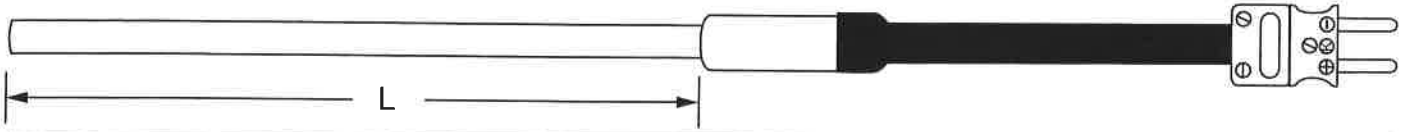

ORDERING INFORMATION:----- 8 - R - 4 - 2K - U - 18 - SH36 - PP20-36

DESIGN TYPE ←

SHEATH MATERIAL ←

- P - 304SS Q - 310SS
- R - 316SS X - OTHER(SPECIFY)
- J - INCONEL 600

SHEATH DIA. ←

- 1 - .062 (1/16") 4 - .250 (1/4")
- 2 - .125 (1/8") 5 - .313 (5/16")
- 3 - .188 (3/16") 6 - .375 (3/8")

THERMOCOUPLE CALIBRATION TYPE ←

- J - Single Iron/Constantan R - Single Platinum/Platinum 13% Rhodium
- 2J - Dual Iron/Constantan 2R - Dual Platinum/Platinum 13% Rhodium
- K - Single Chromel/Alumel S - Single Platinum/Platinum 10% Rhodium
- 2K - Dual Chromel/Alumel 2S - Dual Platinum/Platinum 10% Rhodium
- E - Single Chromel/Constantan B - Single Platinum 30% Rhodium/Platinum 6% Rhodium
- 2E - Dual Chromel/Constantan C - Single (W5Re) Tungsten 5% Rhenium/(W26Re) Tungsten 26% Rhenium
- T - Single Copper/Constantan
- 2T - Dual Copper/Constantan

HOT JUNCTION ←

- G - Grounded E - Exposed
- U - Ungrounded GP - Grounded With Weld Pad
- UI - Ungrounded Isolated (Dual) UP - Ungrounded With Weld Pad

SHEATH "L" LENGTH (SPECIFY IN INCHES) ←

ARMOR MATERIAL AND LENGTH (SPECIFY IN INCHES) ←

- SH - Stainless THS - Teflon Coated Stainless
- PH - PVC Coated Galvanized X - Other-Specify
- PHS - PVC Coated Stainless

LEAD INSULATION & LENGTH (INCHES) ←

- PP - PVC-Solid GGST - Fiberglass Stranded
- GG - Fiberglass-Solid PPSHD - PVC Shielded
- TT - Teflon-Solid X - Other-Specify
- PPST - PVC-Stranded
- TTST - Teflon-Stranded

**Provided With Standard Size Connectors Unless Otherwise Specified.

***If Mating Female Jack Is Required, Add "FJ" After Complete Part Number.

EX: 7SR42KU12-PP20-36-FJ.

THERMOCOUPLE



Thermocouple Type 9

****MgO Insulated Thermocouple With Male Plug**

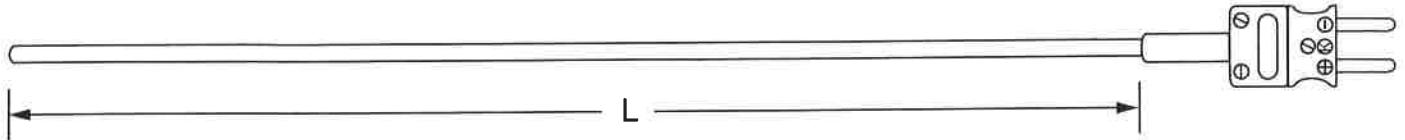

ORDERING INFORMATION:----- 9 - R - 4 - K - U - 24

DESIGN TYPE ←

SHEATH MATERIAL ←

- P - 304SS Q - 310SS
- R - 316SS X - OTHER(SPECIFY)
- J - INCONEL 600

SHEATH DIA. ←

- 1 - .062 (1/16") 4 - .250 (1/4")
- 2 - .125 (1/8") 5 - .313 (5/16")
- 3 - .188 (3/16") 6 - .375 (3/8")

THERMOCOUPLE CALIBRATION TYPE ←

- | | |
|-------------------------------|--|
| J - Single Iron/Constantan | R - Single Platinum/Platinum 13% Rhodium |
| 2J - Dual Iron/Constantan | 2R - Dual Platinum/Platinum 13% Rhodium |
| K - Single Chromel/Alumel | S - Single Platinum/Platinum 10% Rhodium |
| 2K - Dual Chromel/Alumel | 2S - Dual Platinum/Platinum 10% Rhodium |
| E - Single Chromel/Constantan | B - Single Platinum 30% Rhodium/Platinum 6% Rhodium |
| 2E - Dual Chromel/Constantan | C - Single (W5Re) Tungsten 5% Rhenium/(W26Re) Tungsten 26% Rhenium |
| T - Single Copper/Constantan | |
| 2T - Dual Copper/Constantan | |

HOT JUNCTION ←

- | | |
|---------------------------------|-------------------------------|
| G - Grounded | E - Exposed |
| U - Ungrounded | GP - Grounded With Weld Pad |
| UI - Ungrounded Isolated (Dual) | UP - Ungrounded With Weld Pad |

SHEATH "L" LENGTH (SPECIFY IN INCHES) ←

***If Mating Female Jack Is Required, Add"FJ" After Complete Part Number.

EX: 9R4KU12-FJ.

THERMOCOUPLE



Thermocouple Type 10

**Beaded Thermocouples

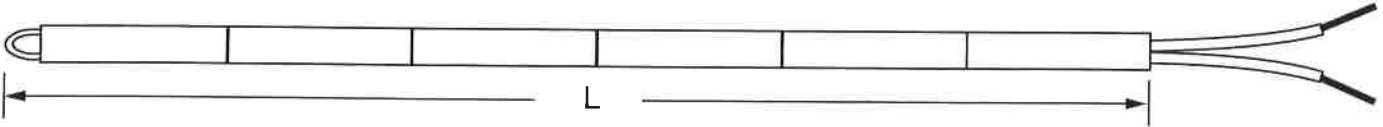

ORDERING INFORMATION:----- 10 - K - 14 - 24

DESIGN TYPE ←

THERMOCOUPLE CALIBRATION TYPE ←

- | | |
|----------------------------|-------------------------------|
| J - Single Iron/Constantan | E - Single Chromel/Constantan |
| JJ - Dual Iron/Constantan | EE - Dual Chromel/Constantan |
| K - Single Chromel/Alumel | T - Single Copper/Constantan |
| KK - Dual Chromel/Alumel | TT - Dual Copper/Constantan |

STANDARD WIRE SIZES (AWG) ←

8, 14, 20, 24 Other Sizes Available

CERAMIC INSULATOR LENGTH (SPECIFY IN INCHES) ←

***Insulator Material Unless Otherwise Specified Are Mullite for J, K, E And T Thermocouples.
Other Materials Are Available. Consult TMS.

**Noble Metal Thermocouples

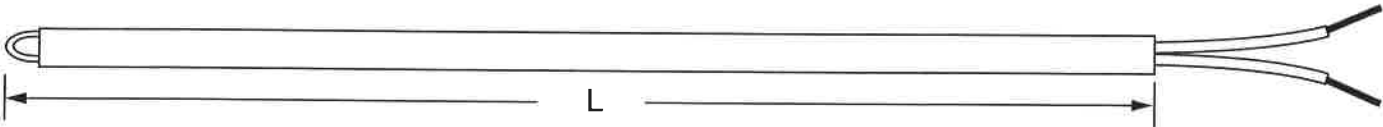

ORDERING INFORMATION:----- 10 - R - 24 - 36

DESIGN TYPE ←

THERMOCOUPLE CALIBRATION TYPE ←

- | | |
|-----------------------------------|--|
| R - Platinum/Platinum 13% Rhodium | B - Platinum 30% Rhodium/Platinum 6% Rhodium |
| S - Platinum/Platinum 10% Rhodium | C - Tungsten 5% Rhenium/Tungsten 26% Rhenium |

WIRE AWG (24 GAUGE STANDARD) ←

CERAMIC INSULATOR LENGTH (SPECIFY IN INCHES) ←

***Other Wire Gauges Available. Consult TMS.

**Insulators Are Alumina For Noble Metal Thermocouples Unless Otherwise Specified.

THERMOCOUPLE



Thermocouple Type 11

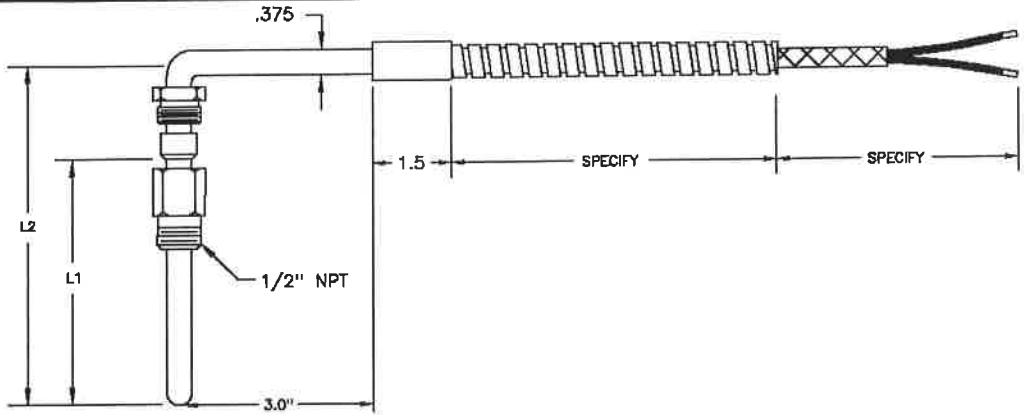

ORDERING INFORMATION:----- 11 - P - 6 - J - G - 6 - 9 - SH - 42 - GG - 16 - 6

DESIGN TYPE ←

SHEATH MATERIAL ←

- P - 304SS
- R - 316SS
- J - INCONEL 600
- Q - 310SS
- X - OTHER(SPECIFY)

SHEATH DIA. ←

- 2 - .125 (1/8")
- 3 - .188 (3/16")
- 4 - .250 (1/4")
- 5 - .313 (5/16")
- 6 - .375 (3/8")

THERMOCOUPLE CALIBRATION TYPE ←

- J - Single Iron/Constantan
- 2J - Dual Iron/Constantan
- K - Single Chromel/Alumel
- 2K - Dual Chromel/Alumel
- E - Single Chromel/Constantan
- 2E - Dual Chromel/Constantan
- T - Single Copper/Constantan
- 2T - Dual Copper/Constantan

HOT JUNCTION ←

- G - Grounded
- U - Ungrounded
- UI - Ungrounded Isolated (Dual)
- E - Exposed

SHEATH "L1" LENGTH (SPECIFY IN INCHES) ←

SHEATH "L2" LENGTH (SPECIFY IN INCHES) ←

ARMOR ←

- SH - Stainless
- PH - PVC Coated Galvanized
- PSH - PVC Coated Stainless Steel
- TH - Teflon Coated Stainless Steel

ARMOR LENGTH IN INCHES ←

LEAD INSULATION ←

- PP - PVC-Solid
- GG - Fiberglass-Solid
- TT - Teflon-Solid
- PPST - PVC-Stranded
- TTST - Teflon-Stranded
- GGST - Fiberglass Stranded
- PPSHD - PVC Shielded
- X - Other-Specify

LEAD INSULATION ←

- 20 AWG
- 16 AWG

LEAD LENGTH IN INCHES ←

THERMOCOUPLE

TMS

Tube Skin Thermocouple Assemblies

Tube skin thermocouple assemblies are used to provide an efficient means of measuring the temperature of vessel walls. Unless otherwise specified, grounded hot junctions are provided to insure quick response. The thermocouples can be designed with an expansion loop to provide flexibility. Weld pads are provided and can be curved to the radius of the vessel to be welded to.

Tube skin thermocouples can be manufactured as shown in the following information or can be manufactured to your specifications. Please consult TMS with any changes to the following design(s) or with your individual specifications.

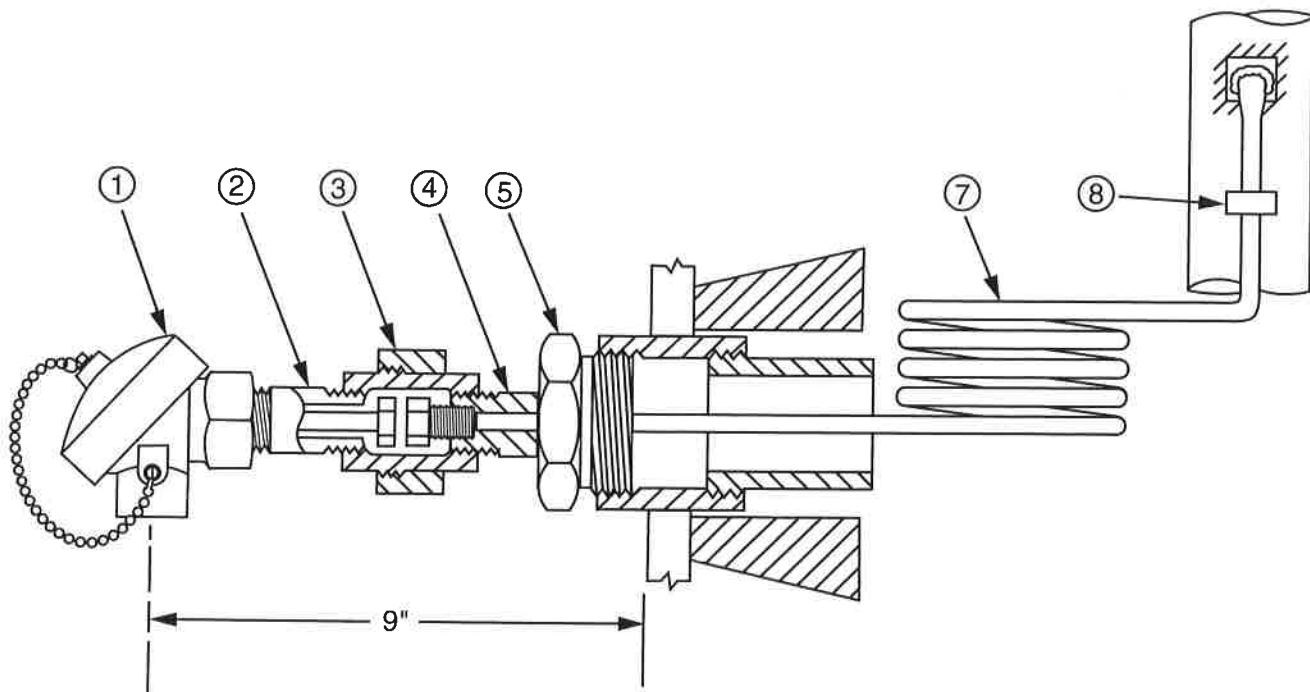

DETAIL NO.	DESCRIPTION
1.	Terminal Head Assembly
2. 3. 4.	Nipple-Union-Nipple 3/4"
5.	Reducing Bushing 1 1/2" X 3/4"
7.	Thermocouple Assembly
8.	Welding Clips (2)

ORDERING INFORMATION

PART NO.	T/C DIAMETER	T/C CALIBRATION	LENGTH	SHEATH MATERIAL
TS - 100	.188 - 3/16"	Chromel/Alumel	Specify	Specify
TS - 101	.188 - 3/16"	Iron/Constantan	Specify	Specify
TS - 102	.250 - 1/4"	Iron/Constantan	Specify	Specify
TS - 103	.250 - 1/4"	Chromel/Alumel	Specify	Specify

Multipoint Thermocouple Assemblies

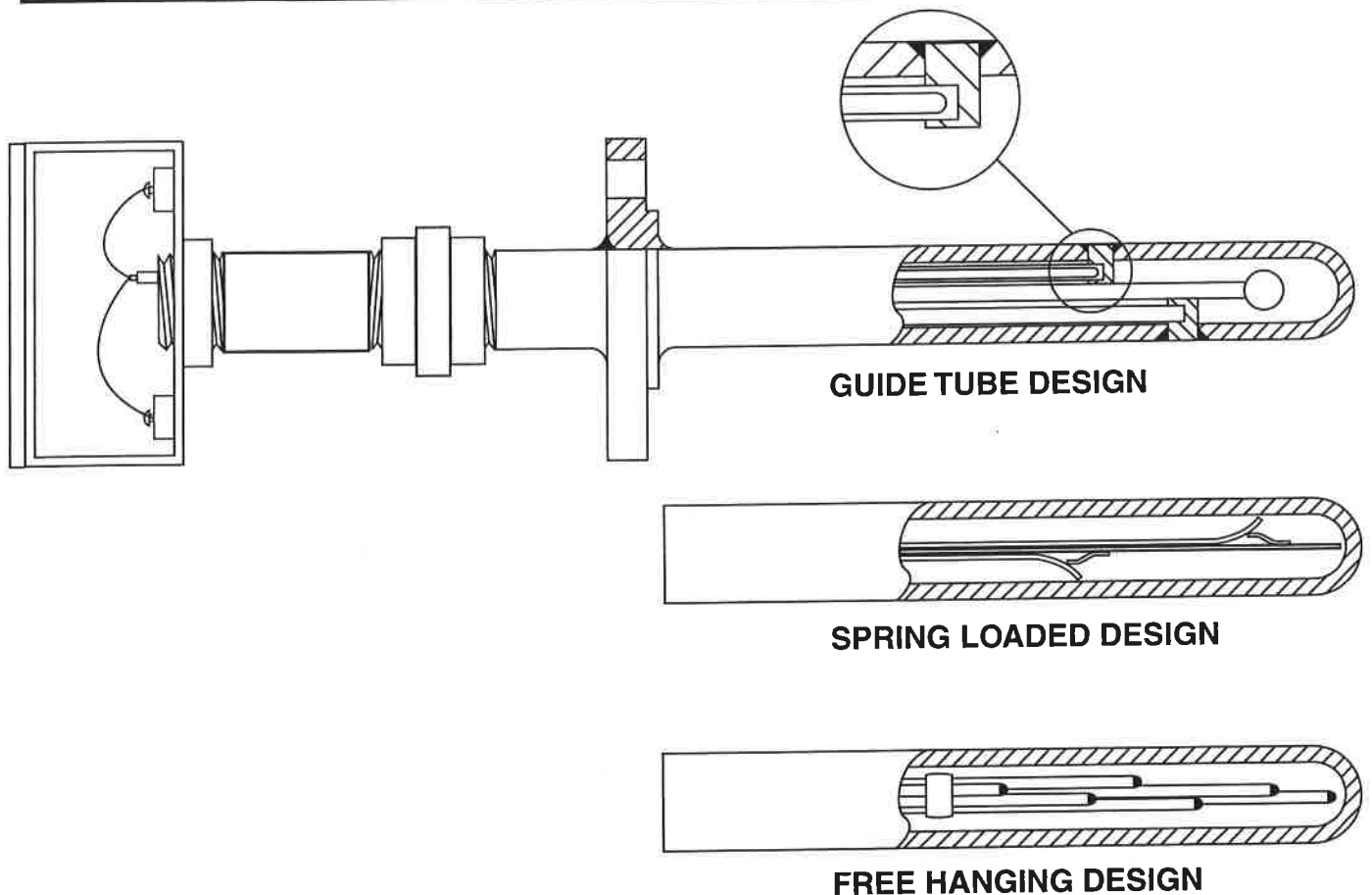

Multipoint Assemblies are manufactured in three basic designs. Due to the many variations that are possible with these designs no ordering information is provided within this literature. Please consult TMS with your individual specifications for these items.

Guide Tube Design - Thermocouple elements are bottomed into a block which is an integral part of the protection tube assembly. The blocks provide increased sensitivity to temperature change. Individual thermocouple elements are easily replaceable without the need to disassemble the entire thermocouple assembly.

Spring Loaded Design - Spring Loaded design forces thermocouple hot junction to come in contact with the inner wall of the thermocouple protection tube providing quick response to temperature change.

Free Hanging Design - Thermocouple elements are manufactured to specified lengths and are secured to a Stainless Steel strap by clamps. The Multipoint thermocouple bundle hangs freely inside the protection tube.

Other designs and configurations are available. Consult TMS.

PROTECT THERMOCOUPLES IN SERVICE - Evaporation, diffusion, oxidation, corrosion, and contamination induce EMF drift due to their effect on the composition of the thermocouple alloys. In as much as these environmental factors are destructive to all common thermocouple alloys, it is essential that proper protection be provided anytime adverse conditions are encountered. In many applications this can be done by using sheath style elements. If bare wire elements are used, the thermoelement must be properly installed in suitable protection tubes or thermowells. When the interior of the protection tube or thermowell is free of sulfur bearing medias and when they are of the proper diameter to length ratios to permit adequate ventilation, they serve very well in overcoming the harmful effects of a corrosive atmosphere.

WIRE SIZE - It is generally true that heavy gauge thermocouples are more stable at high temperatures than finer gauge thermocouples. In many applications, a heavy gauge thermocouple will not satisfy requirements for flexibility and response. A compromise must then be struck between long-term stability of heavier gauges and greater versatility of smaller gauges. Where high temperature stability is necessary, use the largest practical wire size consistent with the other requirements of the job.

LOCATION INSTALLATION - The location of installation of a thermocouple should insure that the temperatures being measured are representative of the equipment and/or media. Direct flame impingement on the thermocouple does not provide a representative temperature.

IMMERSION DEPTH - Since heat conducted away from the hot junction causes the thermocouple to indicate a lower temperature, provide for sufficient depth of immersion of the element into the media to minimize heat transfer along the protection tube. A minimum immersion of ten times the outside diameter of the protection tube should be used.

Under certain conditions, inhomogeneities may gradually develop in a pair of thermocouple wires due to oxidation, corrosion, evaporation, contamination or metallurgical changes. A change in depth of immersion, which shifts such inhomogeneous wire into a steep temperature gradient zone can alter the thermocouple output and produce incorrect readings. Avoid changing the immersion depth of a thermocouple after it has been in service.

EFFECT OF HEATING CYCLES - For maximum accuracy, a thermocouple should be used to control a single temperature or successively higher temperatures only. For various reasons, this procedure cannot always be followed. In many installations, thermocouples continually traverse a broad range of temperatures with adequate results. Errors that arise out of cyclic heating are analogous to those generated by changes in immersion and may range from two or three degrees F. for elements in good condition, to many degrees for thermocouples that are corroded. The type of heating cycle and condition of the thermocouple affects the accuracy obtainable in a specific location. Where cyclic heating cannot be avoided, use top condition thermocouples for maximum accuracy.

PREVENTIVE MAINTENANCE - Thermocouples, protection tubes, and extension wires should be checked periodically. Experience largely determines the frequency of inspection but once a month is normally sufficient.

Check out extension wire by making certain that it meets the established external resistance required.

THERMOCOUPLE

TMS

Damaged or burnt out protection tubes and thermowells should be replaced to prevent damage to the thermocouple.

Thermocouples should be checked in place if possible. If removing the element is necessary, it should be reinserted to the same depth or deeper to avoid errors arising from placing an inhomogeneous segment of wire in a steep temperature gradient.

TROUBLE SHOOTING

When a thermocouple is suspected of giving incorrect readings, the following steps may be taken to isolate the source of error.

1. Circuit - The first step is to check the polarity of the thermocouple circuit and all connections. The positive leg (wire) should be properly connected to the positive side of the instrument. The negative leg (wire) should be properly connected to the negative extension wire which should be connected to the negative side of the instrument. A check at these points will save delays in production. To identify the positive and negative wires follow the following table. Most thermocouples are color coded per ANSI standards. Use of a magnet can check thermocouple types J and K as one leg (wire) is magnetic.

ANSI TYPE	MAGNETIC	NEGATIVE/POSITIVE ANSI COLOR CODE	THERMOCOUPLE ALLOY
J	YES NO	JP - WHITE JN - RED	IRON CONSTANTAN
K	NO YES	KP - YELLOW KN - RED	CHROMEL ALUMEL
E	NO NO	EP - PURPLE EN - RED	CHROMEL CONSTANTAN
T	NO NO	TP - BLUE TN - RED	COPPER CONSTANTAN
R	NO NO	RP - BLACK RN - RED	PLATINUM 13% RHODIUM PURE PLATINUM
S	NO NO	SP - BLACK SN - RED	PLATINUM 10% RHODIUM PURE PLATINUM

INSTRUMENT - If the circuit checks out, the next step is to check the instrument. If a millivolt type meter is used, it should first be checked as to room temperature setting (cold junction compensation). This is done by removing one of the extension wires, either positive or negative, from the meter and observing the meter reading. It should coincide with the room temperature.

If further testing is required, or if the instrument in question is a potentiometer, the working pyrometer set up should be checked by comparing its readings against those obtained with a test thermocouple of known accuracy. In making checks this way, it is important that the test thermocouple be inserted along side the working thermocouple with the hot junction weld beads of both as close as possible. It is also essential that the temperature of both the working and the test meter be the same.

If the test meter reading agrees with that indicated by the working meter the source of trouble is not in the pyrometry circuit but is in the furnace itself. If the test meter reading does not agree with the working meter reading, the following checks should be made to isolate the trouble.

THERMOCOUPLE - Severely corroded or oxidized thermocouples are always a possibility of trouble. Changes in wire composition can result from corrosion and contamination by foreign elements. Impurities such as sulfur and iron plus other factors picked up from furnace refractories, oxide scale, brazing alloys and fluxes constitute possible sources of drift away from initial calibration.

To check the working thermocouple, hook it to the test meter of known accuracy and observe the reading. If the reading is the same as that previously obtained from the test thermocouple of known accuracy, then the working thermocouple is not the problem.

METER AND EXTENSION WIRES - To check the working meter and extension wires, connect the extension wires to the test thermocouple of known accuracy and observe the temperature reading. If the reading is different from that obtained with the test meter, the trouble is either in the extension wires or in the working meter.

EXTENSION WIRE RESISTANCE - If the working meter is the millivolt type, it will have been calibrated for a certain external resistance. Accordingly, the extension wire loop should be checked to make sure that it meets this established external resistance required.

The above checks are intended only as elementary guides in trying to pinpoint the possible cause of erroneous readings. If the cause of erroneous readings can be definitely localized in the thermocouple itself, it should be removed and inspected. A visual inspection, plus a few tests that can be made with hand instruments, will often reveal the condition which caused the thermocouple wires to be out of calibration. Severely corroded or oxidized thermocouples should be replaced. It is usually more economical to replace the thermocouple element than to risk loss of productivity, product or equipment through inaccurate temperature measurement.

SECTION 2

RTD'S



RTD INDEX - SECTION 2

RTD ASSEMBLY ORDERING INFORMATION.....	1
RTD Elements:	
Basic RTD.....	2
With Extended Leads	3
With Armored Extended Leads.....	4
With Double Threaded Fixed Fittings.....	5
With Double Threaded Spring Loaded Fitting.....	6
With Fixed Threaded Fitting.....	7
With Spring Loading Hardware.....	8
RTD Technical Data	9-13

RTD'S

RTD ASSEMBLIES

ORDERING INFORMATION

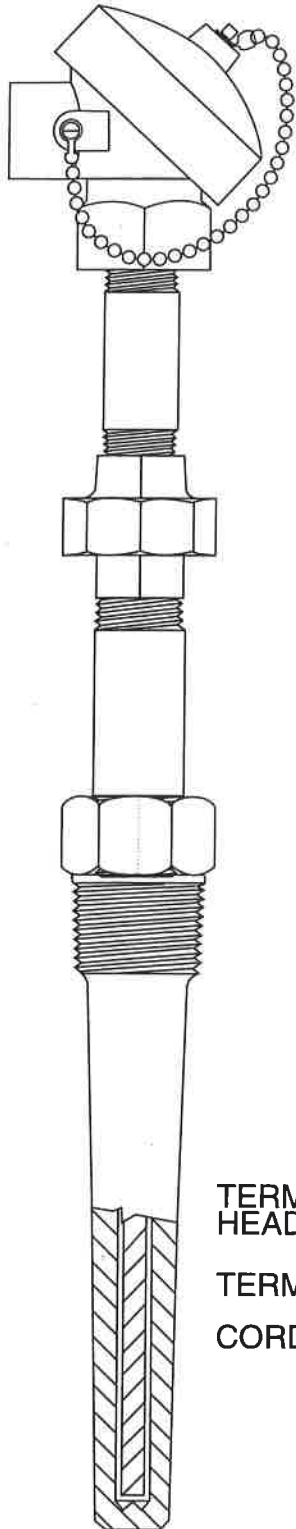

To specify RTD assembly, follow the steps shown below:

For Types 1, 4, S4, and 6:

- Step 1 - Specify Terminal Head from Section 3.
- Step 2 - Specify Terminal Block from Section 3.
- Step 3 - Specify Extension Type (if required) from Section 3.
- Step 4 - Specify RTD Element from Section 2.
- Step 5 - Specify Thermowell or Protection Tube from Section 4.

EXAMPLE:

C2D - U6 - 6P34 - 14 - 103S - R - 4.5

↑ ↑ ↑ ↑

TERMINAL HEAD TERMINAL BLOCK EXTENSION RTD THERMOWELL

For Types 2, and 3:

- Step 1 - Specify Terminal Head from Section 3.
- Step 2 - Specify Terminal Block from Section 3.
- Step 3 - Specify Cord Grip Connector (if required) from Section 6.
- Step 4 - Specify RTD Element from Section 2.
- Step 5 - Specify Compression Fitting (if required) from Section 6.
- Step 6 - Specify Thermowell or Protection Tube (if required) from Section 4.

EXAMPLE:

A2S - G3 - 3P34 - 12 - SH36 - TFE24 - 42 - SA4 - 4 - 703 - R - CVR - 8

↑ ↑ ↑ ↑ ↑ ↑

TERMINAL HEAD TERMINAL BLOCK CORD GRIP CONNECTOR RTD COMPRESSION FITTING THERMOWELL

**FOR TERMINAL HEADS, TERMINAL BLOCKS AND EXTENSIONS
SEE SECTION 3**

RTD SENSOR - TYPE 1

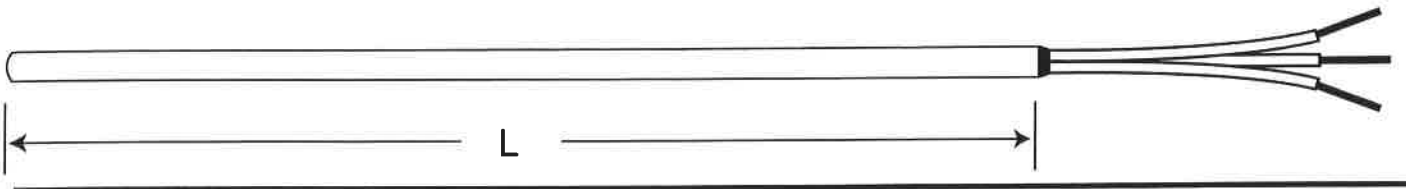

ORDER EXAMPLE----- 1 - 2P - 3 - 4 - 12 - R - 6 - TEMP

DESIGN TYPE ←

SENSOR TYPE ←

P - 100 OHM Platinum	T - 100 OHM Nickel
Q - 200 OHM Platinum	U - 120 OHM Nickel
R - 500 OHM Platinum	V - 10 OHM Copper
S - 1000 OHM Platinum	W - 100 OHM Copper
	X - Other

NO. OF WIRES ←

2,3,4
FOR DUAL 4,6,8

SHEATH DIAMETER* ←

2 - 1/8" (.125)
3 - 3/16" (.188)
4 - 1/4" (.250)
5 - 5/16" (.313)

SHEATH LENGTH IN INCHES ←

SHEATH MATERIAL ←

P - 304SS	J - INCONEL 600
R - 316SS	X - OTHER
Q - 310SS	

LEAD LENGTH IN INCHES ←

MAX. TEMP. RANGE ←

362°F NO CODE
962°F CODE HT**
1112°F CODE HP

For Dual Sensors Designate As 2 + Sensor Code.

EX: Dual 100 OHM Platinum = 2P

* NOTE: For Smaller Diameter Sensors, Consult TMS.

** NOTE: Sensors with Code "HT" will be provided with Fiberglass Leads.

*** NOTE: Sensors with Code "HP" will be provided with Hard Packed RTD.

All HP sensors provided with transition.

Sensors with No Code (362°F) will be provided with Teflon Lead unless otherwise specified.

RTD SENSOR -TYPE 2

Type 2 With Extended Leads

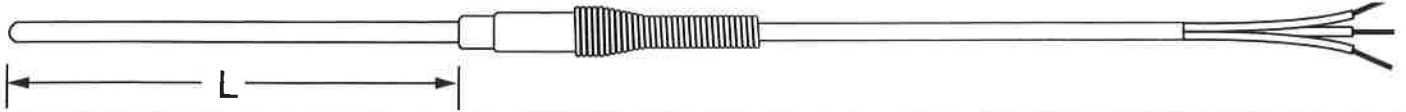

ORDER EXAMPLE----- 2 - U - 4 - 4 - 24 - R - GG - 24 - 36 - TEMP

DESIGN TYPE ←

SENSOR TYPE ←

- | | |
|-----------------------|--------------------|
| P - 100 OHM Platinum | T - 100 OHM Nickel |
| Q - 200 OHM Platinum | U - 120 OHM Nickel |
| R - 500 OHM Platinum | V - 10 OHM Copper |
| S - 1000 OHM Platinum | W - 100 OHM Copper |
| | X - Other |

NO. OF WIRES ←

- 2,3,4
FOR DUAL 4,6,8

SHEATH DIAMETER* ←

- 2 - 1/8" (.125)
3 - 3/16" (.188)
4 - 1/4" (.250)
5 - 5/16" (.313)

"L" LENGTH IN INCHES ←

SHEATH MATERIAL ←

- | | |
|-----------|-----------------|
| P - 304SS | J - INCONEL 600 |
| R - 316SS | X - OTHER |
| Q - 310SS | |

LEAD WIRE INSULATION ←

- TT - Teflon
GG - Fiberglass

LEAD WIRE AWG ←

- 24 AWG Standard

LEAD WIRE LENGTH IN INCHES ←

MAX. TEMP. RANGE ←

- 362°F NO CODE
962°F CODE HT**
1112°F CODE HP

For Dual Sensors Designate As 2 + Sensor Code. EX: Dual 100 OHM Platinum = 2P

* NOTE: For Smaller Diameter Sensors, Consult TMS.

** NOTE: Sensors with Code "HT" will be provided with Fiberglass Leads.

*** NOTE: Sensors with Code "HP" will be provided with Hard Packed RTD.

All HP sensors provided with transition.

Sensors with No Code (362°F) will be provided with Teflon Lead unless otherwise specified.

RTD SENSOR - TYPE 3

Type 3 With Extended Armored Leads

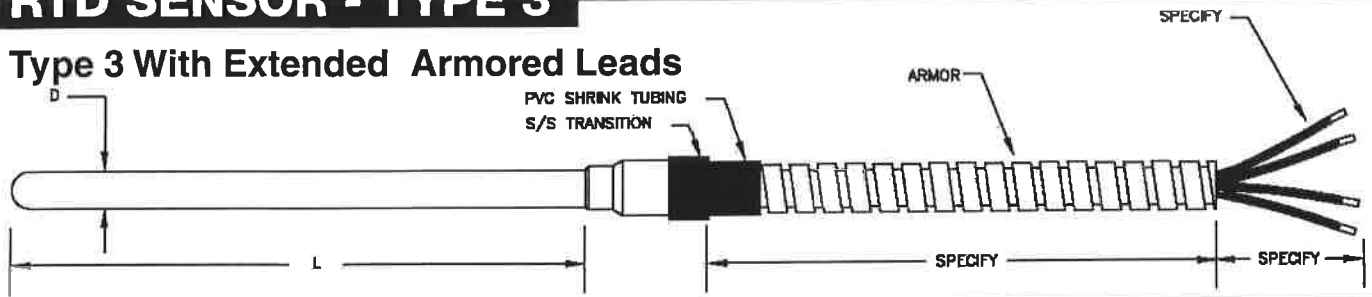

ORDER EXAMPLE----- 3 - 2P - 3 - 4 - 12 - R - TH - 36 - TT - 6 - TEMP

DESIGN TYPE ←

SENSOR TYPE ←

- | | |
|-----------------------|--------------------|
| P - 100 OHM Platinum | T - 100 OHM Nickel |
| Q - 200 OHM Platinum | U - 120 OHM Nickel |
| R - 500 OHM Platinum | V - 10 OHM Copper |
| S - 1000 OHM Platinum | W - 100 OHM Copper |
| | X - Other |

NO. OF WIRES ←

2,3,4
FOR DUAL 4,6,8

SHEATH DIAMETER* ←

2 - 1/8" (.125) 4 - 1/4" (.250)
3 - 3/16" (.188) 5 - 5/16" (.313)

SHEATH LENGTH IN INCHES ←

SHEATH MATERIAL ←

- | | | |
|-----------|-----------------|-----------|
| P - 304SS | Q - 310SS | X - OTHER |
| R - 316SS | J - INCONEL 600 | |

ARMOR ←

- | | |
|----------------------------|------------------------------------|
| SH - Stainless Steel | PSH - PVC Coated Stainless Steel |
| PH - PVC Coated Galvanized | TH - Teflon Coated Stainless Steel |

ARMOR LENGTH IN INCHES ←

LEAD WIRE INSULATION ←

- | | |
|-------------|-----------------|
| TT - Teflon | GG - Fiberglass |
|-------------|-----------------|

LEAD LENGTH IN INCHES ←

MAX. TEMP. RANGE ←

362°F NO CODE 962°F CODE HT** 1112°F CODE HP

For Dual Sensors Designate As 2 + Sensor Code. EX: Dual 100 OHM Platinum = 2P

* NOTE: For Smaller Diameter Sensors, Consult TMS.

** NOTE: Sensors with Code "HT" will be provided with Fiberglass Leads.

*** NOTE: Sensors with Code "HP" will be provided with Hard Packed RTD.

All HP sensors provided with transition.

Sensors with No Code (362°F) will be provided with Teflon Lead unless otherwise specified.

RTD SENSOR - TYPE 4



ORDER EXAMPLE ----- 4 - 2P - 3 - 4 - 12 - R - 6 - TEMP

DESIGN TYPE ←

SENSOR TYPE ←

P - 100 OHM Platinum	T - 100 OHM Nickel
Q - 200 OHM Platinum	U - 120 OHM Nickel
R - 500 OHM Platinum	V - 10 OHM Copper
S - 1000 OHM Platinum	W - 100 OHM Copper
	X - Other

NO. OF WIRES ←

2,3,4
FOR DUAL 4,6,8

SHEATH DIAMETER* ←

2 - 1/8" (.125)
3 - 3/16" (.188)
4 - 1/4" (.250)
5 - 5/16" (.313)

SHEATH LENGTH IN INCHES ←

SHEATH MATERIAL ←

P - 304SS	J - INCONEL 600
R - 316SS	X - OTHER
Q - 310SS	

LEAD LENGTH IN INCHES ←

MAX. TEMP. RANGE ←

362°F NO CODE
962°F CODE HT**
1112°F CODE HP

For Dual Sensors Designate As 2 + Sensor Code. EX: Dual 100 OHM Platinum = 2P

- * NOTE: For Smaller Diameter Sensors, Consult TMS.
- ** NOTE: Sensors with Code "HT" will be provided with Fiberglass Leads.
- *** NOTE: Sensors with Code "HP" will be provided with Hard Packed RTD.
All HP sensors provided with transition.
Sensors with No Code (362°F) will be provided with Teflon Lead unless otherwise specified.

RTD SENSOR - TYPE S4

Type S4 With Double Threaded Spring Loaded Fitting

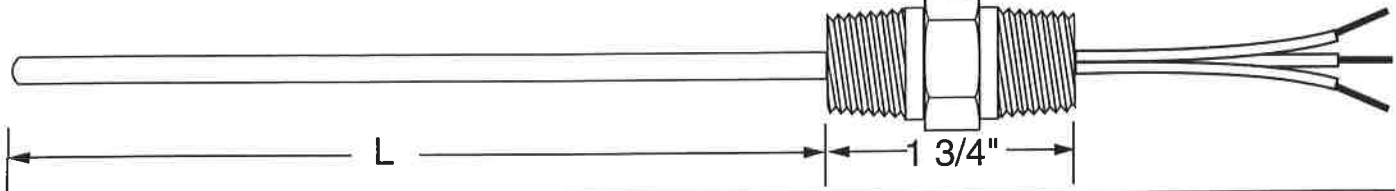

ORDER EXAMPLE-----S4 - 2P - 3 - 4 - 12 - R - 6 - TEMP

DESIGN TYPE ←

SENSOR TYPE ←

- | | |
|-----------------------|--------------------|
| P - 100 OHM Platinum | T - 100 OHM Nickel |
| Q - 200 OHM Platinum | U - 120 OHM Nickel |
| R - 500 OHM Platinum | V - 10 OHM Copper |
| S - 1000 OHM Platinum | W - 100 OHM Copper |
| | X - Other |

NO. OF WIRES ←

- 2,3,4
- FOR DUAL 4,6,8

SHEATH DIAMETER* ←

- 2 - 1/8" (.125)
- 3 - 3/16" (.188)
- 4 - 1/4" (.250)
- 5 - 5/16" (.313)

SHEATH LENGTH IN INCHES ←

SHEATH MATERIAL ←

- | | |
|-----------|-----------------|
| P - 304SS | J - INCONEL 600 |
| R - 316SS | X - OTHER |
| Q - 310SS | |

LEAD LENGTH IN INCHES ←

MAX. TEMP. RANGE ←

- 362°F NO CODE
- 962°F CODE HT**
- 1112°F CODE HP

For Dual Sensors Designate As 2 + Sensor Code. EX: Dual 100 OHM Platinum = 2P

- * NOTE: For Smaller Diameter Sensors, Consult TMS.
- ** NOTE: Sensors with Code "HT" will be provided with Fiberglass Leads.
- *** NOTE: Sensors with Code "HP" will be provided with Hard Packed RTD.

All HP sensors provided with transition.
Sensors with No Code (362°F) will be provided with Teflon Lead unless otherwise specified.

RTD SENSOR - TYPE 5

Type 5 With Fixed Fitting

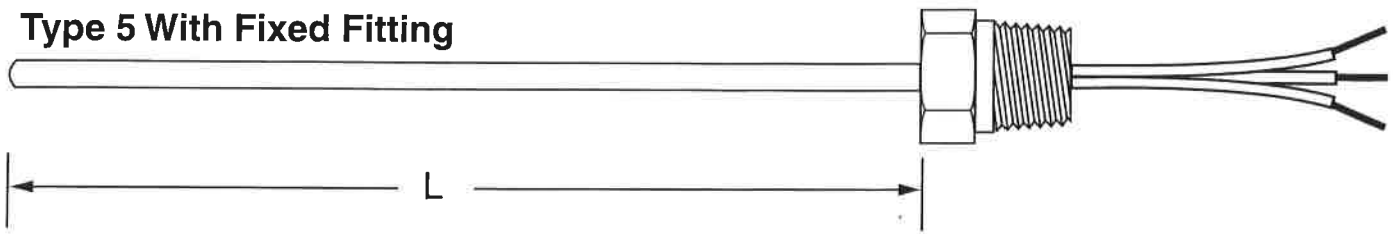

ORDER EXAMPLE ----- 5 - 2P - 3 - 4 - 12 - R - 6 - TEMP

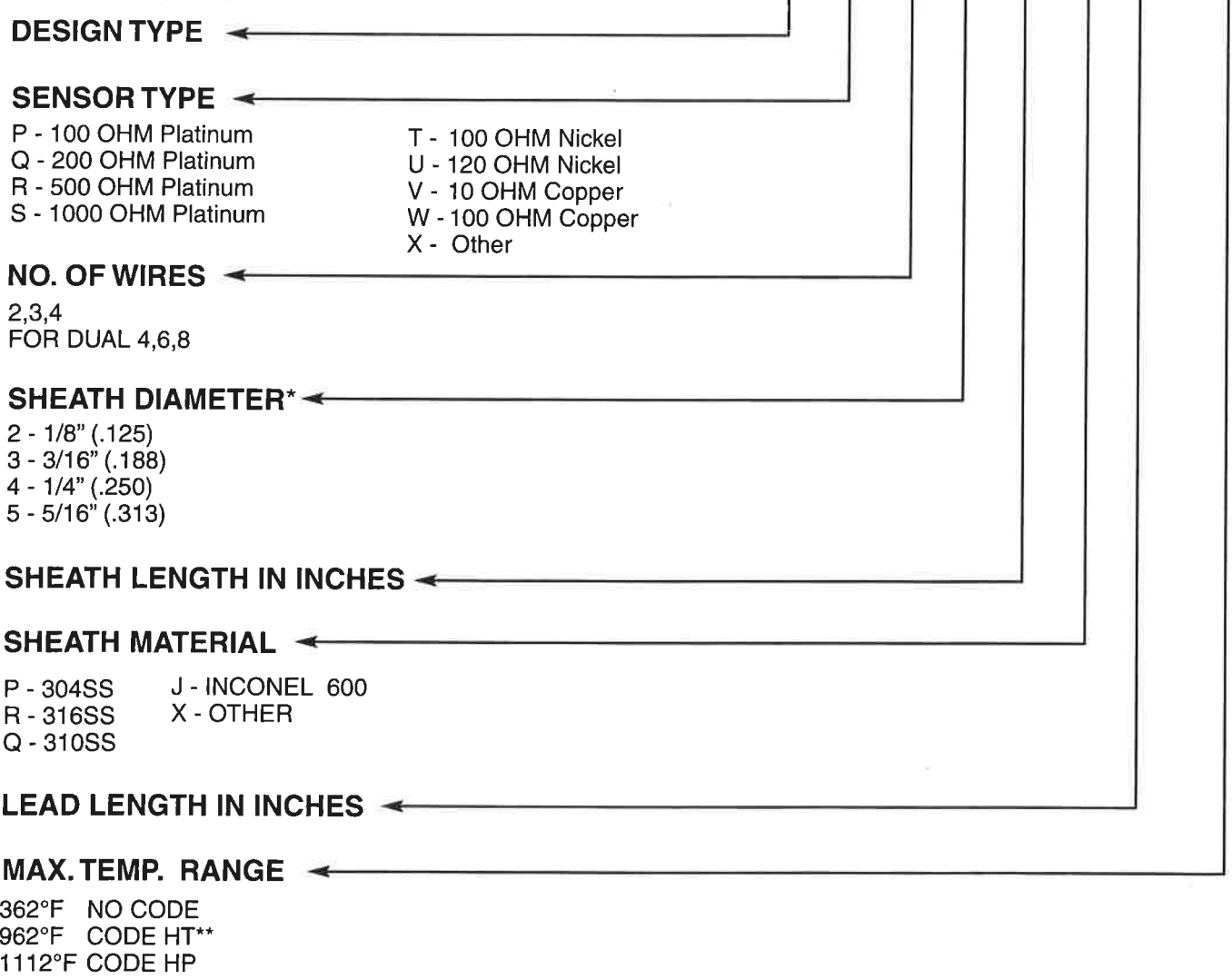

For Dual Sensors Designate As 2 + Sensor Code. EX: Dual 100 OHM Platinum = 2P

* NOTE: For Smaller Diameter Sensors, Consult TMS.

** NOTE: Sensors with Code "HT" will be provided with Fiberglass Leads.

*** NOTE: Sensors with Code "HP" will be provided with Hard Packed RTD.

All HP sensors provided with transition.

Sensors with No Code (362°F) will be provided with Teflon Lead unless otherwise specified.

RTD SENSOR - TYPE 6

Type 6 With Spring Loading Hardware

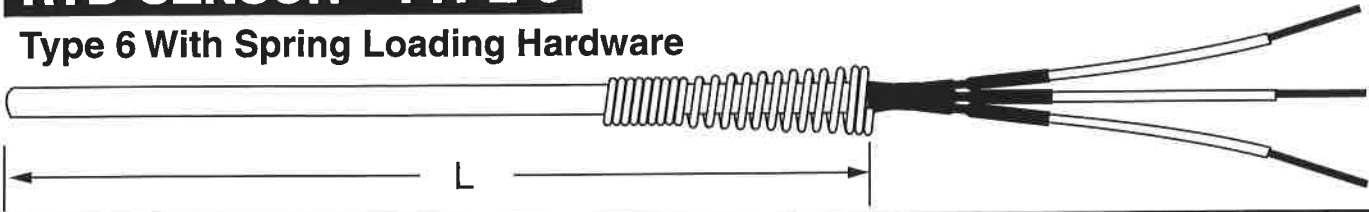

ORDER EXAMPLE----- 6 - 2P - 6 - 4 - 12 - R - 6 - TEMP

DESIGN TYPE ←

SENSOR TYPE ←

- | | |
|-----------------------|--------------------|
| P - 100 OHM Platinum | T - 100 OHM Nickel |
| Q - 200 OHM Platinum | U - 120 OHM Nickel |
| R - 500 OHM Platinum | V - 10 OHM Copper |
| S - 1000 OHM Platinum | W - 100 OHM Copper |
| | X - Other |

NO. OF WIRES ←

- 2,3,4
- FOR DUAL 4,6,8

SHEATH DIAMETER* ←

- 2 - 1/8" (.125)
- 3 - 3/16" (.188)
- 4 - 1/4" (.250)
- 5 - 5/16" (.313)

SHEATH LENGTH IN INCHES ←

SHEATH MATERIAL ←

- | | |
|-----------|-----------------|
| P - 304SS | J - INCONEL 600 |
| R - 316SS | X - OTHER |
| Q - 310SS | |

LEAD LENGTH IN INCHES ←

MAX. TEMP. RANGE ←

- 362°F NO CODE
- 962°F CODE HT**
- 1112°F CODE HP

For Dual Sensors Designate As 2 + Sensor Code. EX: Dual 100 OHM Platinum = 2P

- * NOTE: For Smaller Diameter Sensors, Consult TMS.
- ** NOTE: Sensors with Code "HT" will be provided with Fiberglass Leads.
- *** NOTE: Sensors with Code "HP" will be provided with Hard Packed RTD.

All HP sensors provided with transition.
Sensors with No Code (362°F) will be provided with Teflon Lead unless otherwise specified.

RTD TECHNICAL DATA

TWO LEAD VS. THREE LEAD ELEMENTS.

Measurement of temperature with a resistance temperature detector is a matter of measuring resistance. Unbalanced Wheatstone bridges are invariably used to measure the resistance.

In a resistance temperature detector, the sensing element is usually a small diameter wire, processed in such a manner so that its' resistance will change in a known and repeatable manner relative to temperature. When measuring resistance of the sensing element, all external factors must be minimized or compensated for, in order to obtain an accurate reading. A major cause of error can be the resistance of the leadwires, especially in two lead designs. The resistance of the leadwires is in series with the sensing element, so the readout is the sum of the resistance of the sensing element and leadwires.

Two lead connections are possible when the sensing element has a high resistance and the leadwires have a low resistance.

The leadwire resistance in RTD elements can be high, and must be compensated for in most applications. Compensation for leadwire resistance is possible if resistance temperature detectors are specified as three lead constructions.

Three lead connections are recommended for resistance temperature detectors having low sensing element resistance, where small lead wire resistance can have a large effect on readout accuracy.

APPLICATION GUIDE

EFFECT OF LEADWIRE ON RTD ACCURACY:

The majority of RTD sensor applications standardize on three or four leadwire systems. The difference between the two constructions is accuracy.

Most manufacturers will specify accuracy as 0.1% or a similar figure. This percentage refers to how tightly the RTD bulb is calibrated at one temperature and does not reflect the total sensor accuracy after leadwire is attached to the element.

Since a RTD is a resistance type sensor, any resistance in the extension wire between the RTD and control instrument will add to the readings. This added resistance is not constant because copper in leadwires change resistance with changing temperature. Errors may be nearly canceled by using a three wire construction.

LEADWIRE COMPENSATION:

Because an RTD is a resistance device, any resistance in the leadwires between the sensor and the instrument will add resistance to the circuit and alter the readings. Compensating for this extra resistance with adjustments at the instrument may be possible. Variations in ambient temperature alter copper leadwire resistance so this only works when leadwires are held at a constant temperature.

To approximate the error in a uncompensated sensor circuit, multiply the length (in feet) of both extension leads by the approximate value of the gauge wire used. Divide it by the sensitivity of the element to obtain an error value in degrees C. For example, assume a 100 ohm platinum element with 0.0385 TCR and 24 AWG leads, 150 ft. long:

Total Resistance = 300 ft. X 0.0262 ohms/ft. = 7.86 ohms
 Approximate Error = 7.86 ohms/(0.385 ohm/deg. C) = 20.42 deg. C.

LEADWIRE AWG.	OHMS/FT @ 25°C	BASE RESISTANCE	SENSITIVITY
20 AWG	0.0103	.03926	0.392
22 AWG	0.0165	.00391	0.391
24 AWG	0.0262	.00385	0.385

RTD ACCURACY:

RTD ACCURACY - TIME CONSTANT (THERMAL RESPONSE)

An RTD sensing element like any other thermometer, senses its own temperature. Since you're actually interested in the temperature of the surrounding medium, accuracy depends on the ability of the RTD to conduct heat from its outer sheath to the element wire.

Several factors come into play. The most commonly noted is time constant (Thermal Response Time). What is Time Constant?

TIME CONSTANT

Time Constant or Thermal Response Time, is an expression of how quickly a sensor, in this case an RTD, responds to temperature changes. As expressed here, time response is defined as how long it takes a sensor to reach 63.2% of a step temperature change (Figure 1).

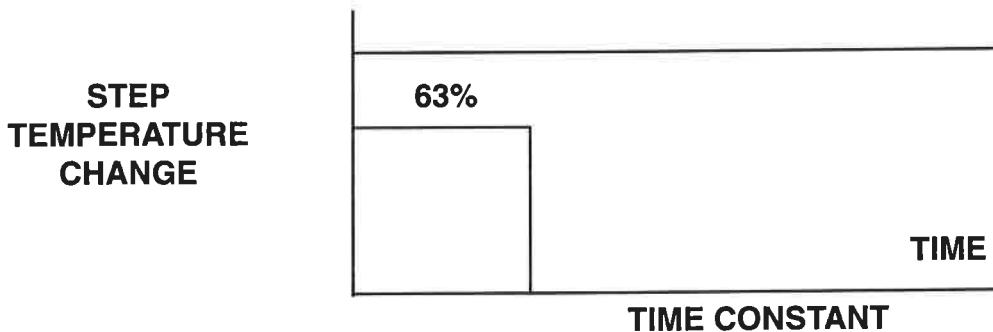

Response is a function of the mass of the sensor and its efficiency in transferring heat from its outer surfaces to the wire sensing element. A rapid time response is essential for accuracy in a system with sharp temperature changes. Time response varies with the probe's physical size and actual element mass.

Response characteristics can be altered by changes in element sizes, sheath diameter, wall thickness, and special packaging techniques. One common alteration is to manufacture a probe with copper tip to improve thermal sensitivity.

The bottom line is that you can often improve performance with careful design and material selection, but more often than not, the standard probe provides response characteristics to meet the vast majority of industry applications.

INTERCHANGEABILITY - AN APPLICATION AID

Interchangeability is a common cited factor of RTD accuracy. It tells how closely the sensing element of a RTD follows its nominal resistance/temperature curve, and the maximum variation that should exist in the readings of identical thermometers, mounted side by side under identical conditions.

Interchangeability consists of both a tolerance at one reference temperature, usually 0 Deg. C, and a Tolerance of the slope, or temperature coefficient of resistance (TCR). For example, the standard German specification is DIN43760. A class "B" resistor requires the R_0 to be $100 \pm .12$ OHM, with a TCR of $.00385 \pm .000012$ OHM/OHM Deg. C. Because the slope may vary slightly, the tightest conformity to the nominal curve is at 0 Deg. C. For example tolerance is $\pm .3$ Deg. C at 0 Deg. C but ± 3.8 Deg. C at 700 Deg. C.

Even a slight deviation in the TCR will cause a significant error to result at elevated temperature, thus, it is important for the user to specify the TCR when ordering RTD probes. Often users request the manufacturer's standard 100 OHM probes, when in fact manufacturers are not all working from the same standard or TCR.

Today U.S. industry is leaning toward the DIN 43760 standard with a TCR of $.00385/\text{OHM}/\text{OHM}/\text{C}$. However, until this standard is adopted by the governing agencies, manufacturers produce resistors (RTD'S) to several different TCRs.

Figure 1 shows a 2 lead RTD connected to a typical Wheatstone Bridge Circuit. E_s is the supply voltage; E_o is the output voltage; R_1 , R_2 , R_3 are fixed resistors; and R_t is the RTD. In this circuit, lead resistances L_1 and L_2 add directly to R_T .

**FIGURE 1
2 WIRE
CIRCUIT**

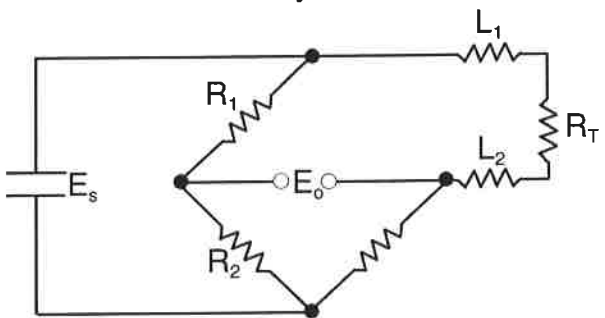

In the 3-wire circuit shown in figure 2, the identical measuring current flows through L_1 and L_2 , canceling their resistance, since they're in two separate arms of the bridge. L_3 connected to E_o is used only as a potential lead; no current flows through it when the bridge is balanced. This method of leadwire compensation depends on close matching of the resistance in L_1 and L_2 and high impedance at E_o , since any current flow in L_3 will cause errors.

**FIGURE 2
3 WIRE
CIRCUIT**

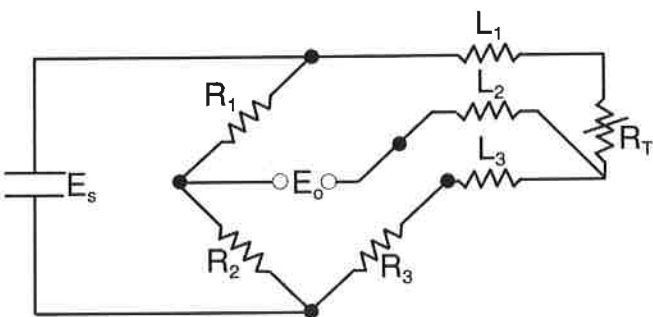

Four wire circuits offer the ultimate performance over extreme distances, or where small errors such as contact resistance becomes significant. Although many laboratory systems employ resistive networks for 4 wire compensation, the most common industrial circuit drives a constant current through the leads, and measures voltage drop across the remaining two (see Figure 3). Assuming that input impedance prevents current flow in L_2 and L_3 , the only significant source of error is variation in the measuring current.

**FIGURE 2
4 WIRE
CIRCUIT**

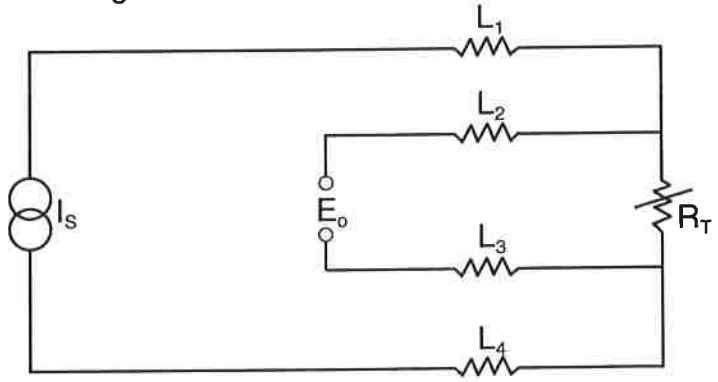

If necessary, you can connect a 2 wire RTD to a 3 wire circuit or a 3 wire RTD to a 4 wire circuit. Just attach the extra extension wires to the ends of the RTD leads, as shown in Figure 4. As long as these connections are close to the sensing element, as in a connection head, errors should be negligible..

**FIGURE 4
ADDING
EXTRA
LEADS**

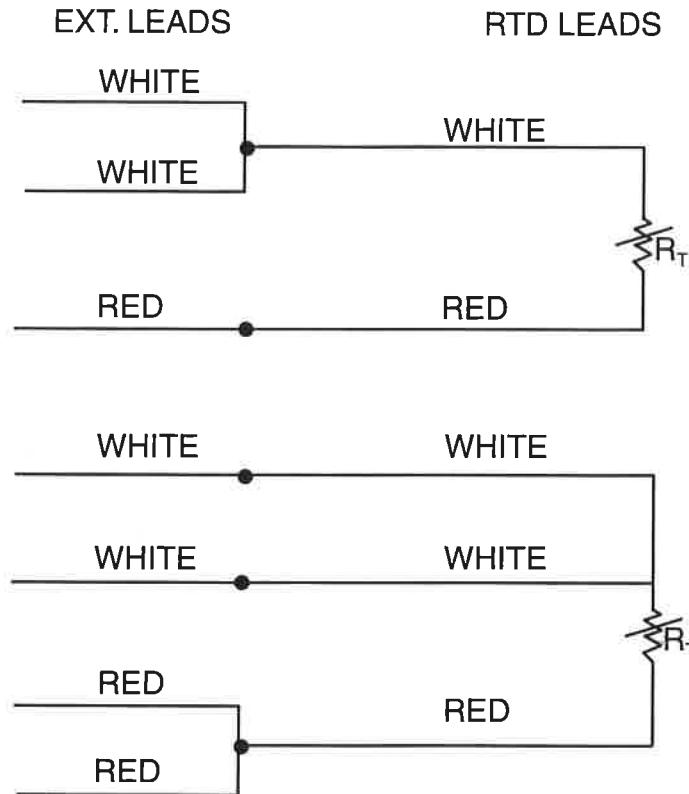

TMS RTD sensors are manufactured from elements that are in conformance with DIN 43760, JIS C 1604 and IEC 751 standards.

DIN 43760 specifies resistance curves and tolerances for platinum and nickel RTD elements. Platinum elements measure 100 ohms at 0 degrees C and have a TCR of .00385 ohms/ohms C. DIN 43760 specifies two tolerances. These tolerances are:

Class A: +/- .06% at 0 degrees C.

Class B: +/- .12% at 0 degrees C.

IEC 751 specifies for the same 100 ohm platinum curve and tolerances as DIN 43760 but includes additional specifications for design and testing of specific thermometers.

JIS C 1604 specifies 100 ohm .00385 platinum thermometers in accordance with IEC 751 but also makes provisions for TCR .003916.

SECTION 3

TERMINAL HEADS, TERMINAL BLOCKS, AND EXTENSIONS

TERMINAL HEADS, TERMINAL BLOCKS AND EXTENSIONS INDEX - SECTION 3

Terminal Heads:

Aluminum/Cast Iron	1
Small Cast Aluminum	1
Stainless Steel	1
Screw Cover Polypropylene	2
Hinged Cover Polypropylene and Aluminum	2
Explosion Proof	2
Explosion Proof – Certified	3

Terminal Blocks:

Ceramic Terminal Blocks	4
Barrier Blocks	4
Barrier Blocks Sectional	4
Oval Terminal Blocks	5
Mini Round Terminal Blocks	5
Round Ceramic Terminal Blocks	5

Extensions:

Nipple Assemblies	6
Nipple-Union Assemblies	6
Nipple-Union-Nipple Assemblies	6

TERMINAL HEAD

TMS

TERMINAL HEADS

General Purpose - Weather- Proof

ALUMINUM / CAST IRON

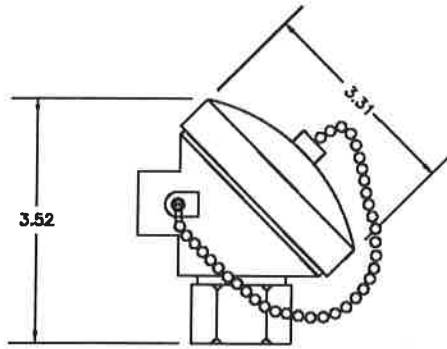

PART NO.	CONDUIT CONNECTION	INSTRUMENT CONNECTION
A1	1/2" NPT	1/2" NPT
A2	3/4" NPT	1/2" NPT
A3	3/4" NPT	3/4" NPT
A4	3/4" NPT	1" NPT
C1	1/2" NPT	1/2" NPT
C2	3/4" NPT	1/2" NPT
C3	3/4" NPT	3/4" NPT
C4	3/4" NPT	1" NPT

Compatible with Terminal Blocks: TA2, TB4, & TH6.
See Section 3 pages 4-5 for Terminal Blocks.

SMALL CAST ALUMINUM

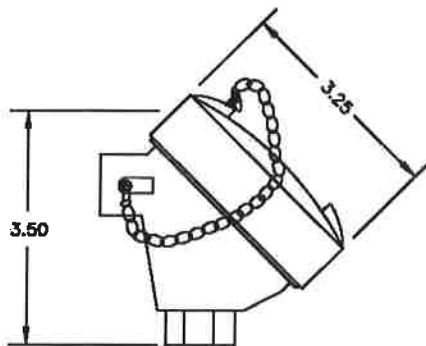

PART NO.	CONDUIT CONNECTION	INSTRUMENT CONNECTION
A5	1/2" NPT	1/2" NPT
A6	3/4" NPT	1/2" NPT
A7	3/4" NPT	3/4" NPT

Compatible with Hockey Puck style Transmitter and
Terminal Blocks TF2, TG4 & TH6
See Section 3 pages 4-5 for Terminal Blocks.

STAINLESS STEEL

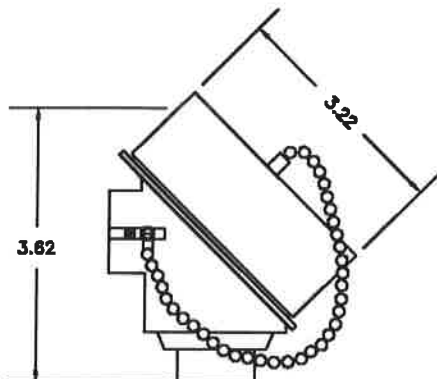

PART NO.	CONDUIT CONNECTION	INSTRUMENT CONNECTION
S1	1/2" NPT	1/2" NPT
S2	3/4" NPT	1/2" NPT
S3	3/4" NPT	3/4" NPT

Compatible with Terminal Blocks: TC2, TD4, & TE6.
See Section 3 pages 4-5 for Terminal Blocks.

TERMINAL HEAD



TERMINAL HEADS

General Purpose - Weather- Proof

SCREW COVER - POLYPROPYLENE

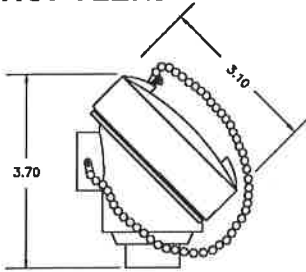

PART NO.	CONDUIT CONNECTION	INSTRUMENT CONNECTION	COLOR
P2	1/2" NPT	1/2" NPT	BLACK
P3	3/4" NPT	1/2" NPT	FDA APPROVED WHITE
P4	3/4" NPT	1/2" NPT	BLACK

Compatible with Terminal Blocks: TA2, TB4, & TH6.

HINGED COVER - FLIP TOP TERMINAL HEADS

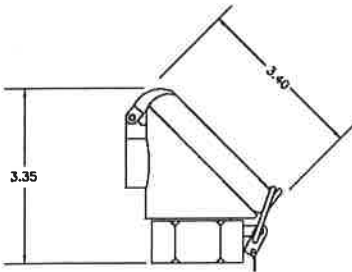

PART NO.	MATERIAL AND COLOR	CONDUIT CONNECTION	INSTRUMENT CONNECTION
H1	FDA APPROVED WHITE POLYPROPYLENE	3/4" NPT	1/2" NPT
H2	FDA APPROVED WHITE POLYPROPYLENE	3/4" NPT	3/4" NPT
H3	BLACK POLYPROPYLENE	3/4" NPT	1/2" NPT
H4	BLACK POLYPROPYLENE	3/4" NPT	3/4" NPT
H5	ALUMINUM	1/2" NPT	1/2" NPT
H6	ALUMINUM	3/4" NPT	1/2" NPT
H7	ALUMINUM	3/4" NPT	3/4" NPT

Compatible with Terminal Blocks: TF2, TG4, TH6.

EXPLOSION PROOF

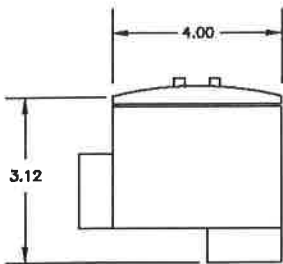

PART NO.	CONDUIT CONNECTION	INSTRUMENT CONNECTION
EB1	1/2" NPT	1/2" NPT
EB2	3/4" NPT	1/2" NPT
EB3	3/4" NPT	3/4" NPT

Compatible with Terminal Blocks: TA2, TB4, TH6, BB4, & BB6.

EXPLOSION PROOF

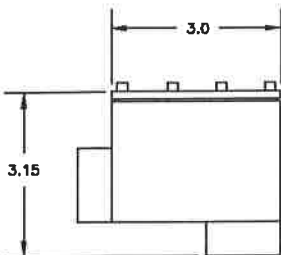

PART NO.	CONDUIT CONNECTION	INSTRUMENT CONNECTION
EB4	1/2" NPT	1/2" NPT
EB5	3/4" NPT	3/4" NPT
EB6	1.0" NPT	1.0" NPT

Compatible with Terminal Blocks: TA2, TB4 & TH6.

TERMINAL HEAD

TMS

TERMINAL HEADS

General Purpose - Weather- Proof

EXPLOSION PROOF

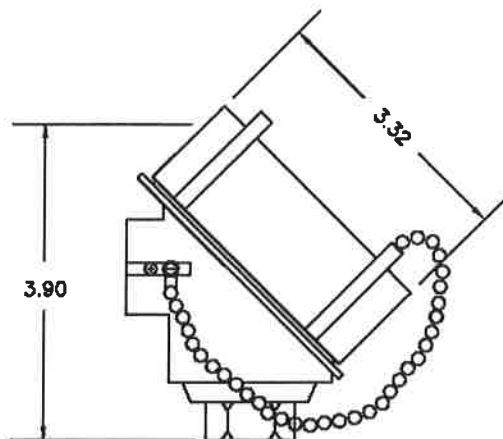

PART NO.	CONDUIT CONNECTION	INSTRUMENT CONNECTION	MATERIAL	CERTIFICATION
F1	1/2" NPT	1/2" NPT	Aluminum	FM/CSA
F2	3/4" NPT	1/2" NPT	Aluminum	FM/CSA
F3	3/4" NPT	3/4" NPT	Aluminum	FM/CSA
F4	M20 X 1.5	1/2" NPT	Aluminum	FM/CSA
F5	1/2" NPT	1/2" NPT	S/S	FM/CSA
F6	3/4" NPT	1/2" NPT	S/S	FM/CSA
F7	3/4" NPT	3/4" NPT	S/S	FM/CSA
F8	M20 X 1.5	1/2" NPT	S/S	FM/CSA
FA1	1/2" NPT	1/2" NPT	Aluminum	ATEX
FA2	3/4" NPT	1/2" NPT	Aluminum	ATEX
FA3	3/4" NPT	3/4" NPT	Aluminum	ATEX
FA4	M20 X 1.5	1/2" NPT	Aluminum	ATEX
FA5	1/2" NPT	1/2" NPT	S/S	ATEX
FA6	3/4" NPT	1/2" NPT	S/S	ATEX
FA7	3/4" NPT	3/4" NPT	S/S	ATEX
FA8	M20 X 1.5	1/2" NPT	S/S	ATEX

Compatible with Hockey Puck style Transmitter and Terminal Blocks TC2, TD4 & TE6.

TERMINAL/BARRIER BLOCK TMS

TERMINAL AND BARRIER BLOCKS

CERAMIC TERMINAL BLOCKS

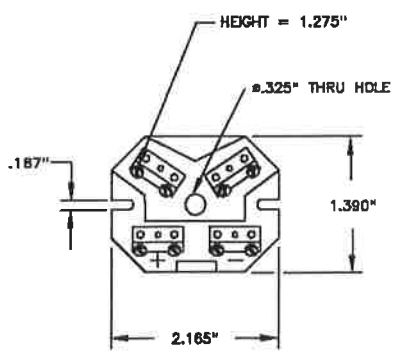

TB4 - DUAL TERMINAL BLOCK

CODE	PART NUMBER & DESCRIPTION
S	TA2 - Single Terminal Block
D	TB4 - Dual Terminal Block

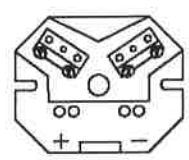

TA2 - SINGLE TERMINAL BLOCK

STANDARD BARRIER BLOCKS

UNCOMPENSATED

COMPENSATED

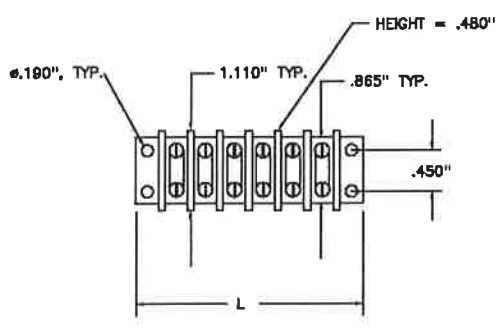

PART NO.	NO. OF TERMINALS
BB2	2
BB4	4
BB6	6
BB8	8
BB10	10
BB12	12
BB14	14

PART NO.	NO. OF TERMINALS	CALIBRATION
CBB2	2	J, K, T, E
CBB4	4	J, K, T, E
CBB6	6	J, K, T, E
CBB8	8	J, K, T, E
CBB10	10	J, K, T, E
CBB12	12	J, K, T, E
CBB14	14	J, K, T, E

Miniature barrier blocks available in uncompensated only. Specify part no. with code "A" ex. BB2-A.

SECTIONAL BARRIER BLOCKS

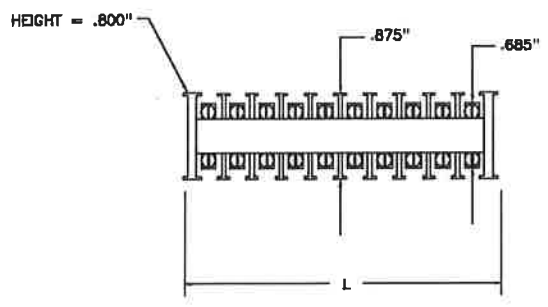

PART NO.	NO. OF TERMINALS
SBB2	2
SBB4	4
SBB6	6
SBB8	8
SBB10	10
SBB12	12
SBB14	14
SBB16	16

To Order, Specify Part Number And Calibration

TERMINAL/BARRIER BLOCK



TERMINAL AND BARRIER BLOCKS

OVAL CERAMIC TERMINAL BLOCKS

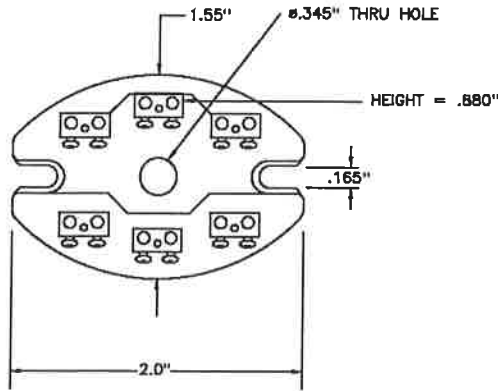

CODE	PART NUMBER & DESCRIPTION
S	TF2 -Single Terminal Block
D	TG4 - Dual Terminal Block
T	TH6 - TRIPLEX TERMINAL BLOCK

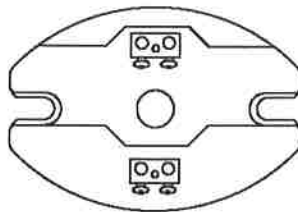

TF2 - SINGLE TERMINAL BLOCK

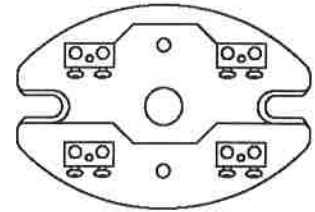

TG4 - DUAL TERMINAL BLOCK

MINI ROUND CERAMIC TERMINAL BLOCK

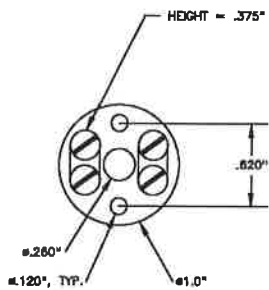

CODE	PART NUMBER & DESCRIPTION
S	T12 -Single Terminal Block

ROUND CERAMIC TERMINAL BLOCK

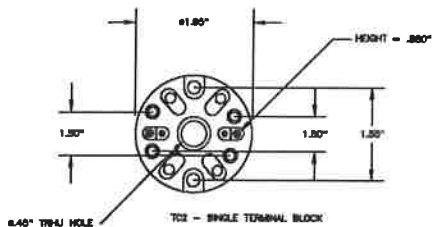

CODE	PART NUMBER & DESCRIPTION
S	TC2 -Single Terminal Block
D	TD4 - Dual Terminal Block
T	TE6 - TRIPLEX TERMINAL BLOCK

To Order, Specify Part Number And Calibration



TD4 - DUAL TERMINAL BLOCK



TE6 - TRIPLEX TERMINAL BLOCK

NIPPLE / UNION



EXTENSIONS

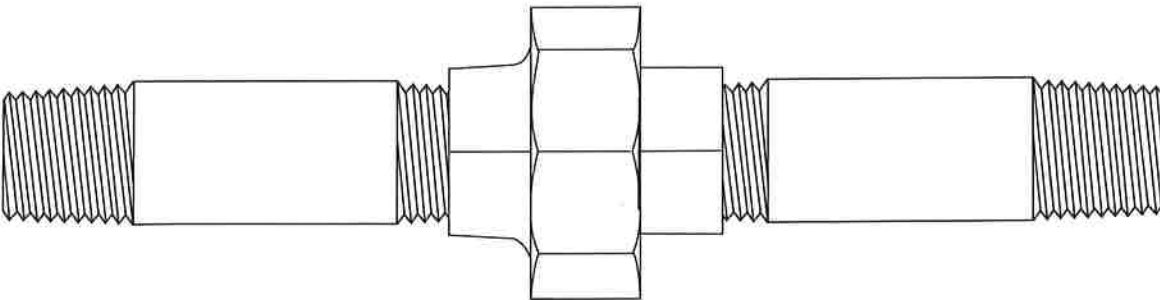
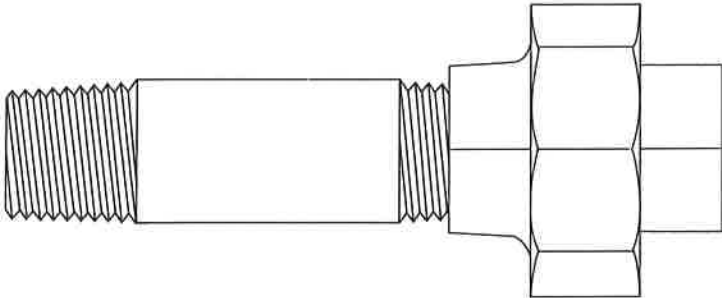

EXTENSION CODE	CONSTRUCTION
N	NIPPLE ONLY
U	NIPPLE-UNION-NIPPLE
UN	UNION-NIPPLE
CN	COUPLING-NIPPLE

MATERIAL CODE	MATERIAL
NO CODE	GALVANIZED STEEL
B	BLACK IRON
SS	304SS
R	316SS
X	OTHER

Specify extension code, extension length and material. Extension thread size is determined by the terminal head and thermowell connections.

Example: U4SS (Nipple-Union-Nipple, 4", 304SS Material)

If ordering extension only, specify code, extension length, material and thread size.

Example: U4SS-1/2" NPT (Nipple-Union-Nipple 4", 304SS Material, 1/2" NPT)

SECTION 4

THERMOWELLS



THERMOWELLS INDEX - SECTION 4:

Straight and Tapered Threaded.....	1
Barstock Thermowells	1
Metallic Protection Tubes: Plain, with Mounting Bushing and Flanged Connections	2
Socket Weld, Straight and Tapered	3
Weld-in Thermowells.....	3
Flanged Thermowells: Straight and Tapered.....	3
Flanged Tantalum Sleeve Thermowells.....	4
Van Stone Thermowells	4
Sample Probes	5
Large Bore Thermowells	5
Ceramic Protection Tubes: Plain, with Hex Nipple, with Standard Nipple.....	6
Threaded Bimetal Thermometer Wells.....	7
Flanged Wells for Bimetal Thermometers	8
Socket Weld Bimetal Thermometer Wells	8
Plugs and Chains.....	9
Material Codes.....	9
Material Specifications	10
Specialty Thermowells	11
Services: Coatings, Hard Facings, Testing and Calculations	11
Technical Data	12
Warranty.....	13

THERMOWELLS



Straight-Threaded Barstock-100S Series

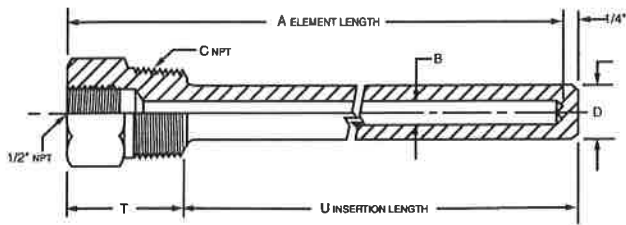

Order Example
103S - R - 4.5 - 1.75

Basic Part No. →
Material Code From Section 4, page 9 →
T Length Including Lag →
U Insertion Length →

PART No.	"A" HEX SIZE	"B" BORE	"C" NPT	"D" STEM DIA.	"T" LENGTH
100S	1.125	.265	1/2"	.625	1.75
101S	1.125	.390	1/2"	.625	1.75
102S	1.125	.390	3/4"	.750	1.75
103S	1.125	.265	3/4"	.750	1.75
104S	1.125	.515	3/4"	.875	1.75
105S	1.125	.437	3/4"	.750	1.75
106S	1.375	.515	1"	.875	1.75
107S	1.375	.437	1"	.875	1.75
108S	1.375	.390	1"	.875	1.75
109S	1.375	.265	1"	.750	1.75

***Other Sizes Available - Consult TMS

MATERIAL	TEMPERATURE - DEGREES F						
	70	200	400	600	800	1000	1200
Brass	5000	4200	1000	-----	-----	-----	-----
Carbon Steel	5200	5000	4800	4600	3500	1500	-----
304S/S	7000	6200	5600	5400	5200	4500	650
316S/S	7000	7000	6400	6200	6100	5100	2500
Monel	6500	6000	5400	5300	5200	1500	-----

Tapered-Threaded Barstock-100T Series

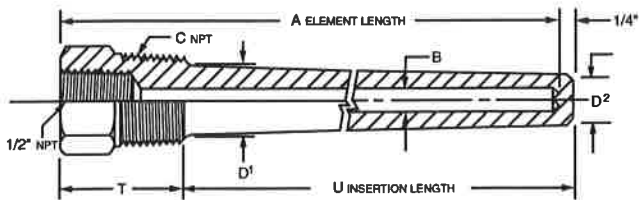

Order Example
103T - P - 6 - 1.75

Basic Part No. →
Material Code From Section 4, page 9 →
T Length Including Lag →
U Insertion Length →

PART No.	"A" HEX SIZE	"B" BORE	"C" NPT	D1 DIA.	D2 DIA.	"T" LENGTH
100T	1.125	.265	1/2"	.688	.625	1.75
101T	1.125	.390	1/2"	.688	.625	1.75
102T	1.125	.390	3/4"	.875	.750	1.75
103T	1.125	.265	3/4"	.875	.750	1.75
104T	1.125	.515	3/4"	.875	.750	1.75
105T	1.125	.437	3/4"	.875	.750	1.75
106T	1.375	.515	1"	1.000	.750	1.75
107T	1.375	.437	1"	1.000	.875	1.75
108T	1.375	.390	1"	1.000	.750	1.75
109T	1.375	.265	1"	1.000	.750	1.75

***Other Sizes Available - Consult TMS

MATERIAL	TEMPERATURE - DEGREES F						
	70	200	400	600	800	1000	1200
Brass	5000	4200	1000	-----	-----	-----	-----
Carbon Steel	5200	5000	4800	4600	3500	1500	-----
304S/S	7000	6200	5600	5400	5200	4500	650
316S/S	7000	7000	6400	6200	6100	5100	2500
Monel	6500	6000	5400	5300	5200	1500	-----

THERMOWELLS



METALLIC PROTECTION TUBES

Tubes-No Bushings

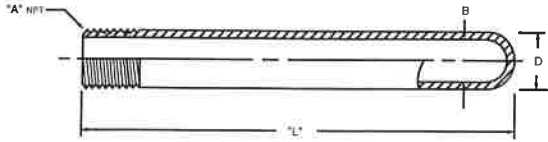

Order Example

203 - R - 12

Basic Part No. Material Code "L" Length
From Section 4, page 9

PART NO.	"A" NPT	"B" BORE	"D" DIA.
200	1/4"	.364	.540
201	1/4"	.302	.540
202	1/2"	.622	.843
203	1/2"	.546	.843
204	3/4"	.824	1.050
205	3/4"	.742	1.050
206	1"	1.049	1.312
207	1"	.957	1.312

Tubes-With Mounting Bushing

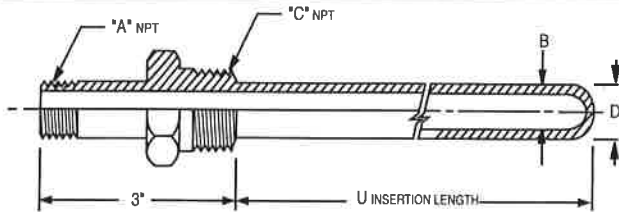

Order Example

302 - R - 12 - 3

Basic Part No. Material Code "T" Length
U Insertion Length
From Section 4, page 9

PART NO.	"A" NPT	"B" BORE	"C" NPT	"D" DIA.
300	1/4"	.364	1/2"	.540
301	1/2"	.622	3/4"	.843
302	1/2"	.622	1"	.843
303	1/2"	.622	1 1/2"	.843
304	3/4"	.824	1"	1.050
305	3/4"	.824	1 1/2"	1.050
306	1"	1.049	1 1/2"	1.312
307	1"	1.049	2"	1.312

Tubes-Flanged

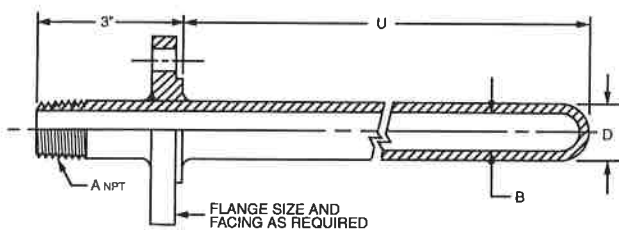

Order Example

401 - R - CUR - 12 - 3

Basic Part No. Material Code Flange Code "U" Insertion Length
From Section 4, page 9 From Chart

PART NO.	"A" NPT	"B" BORE	"D" DIA.
400	1/4"	.364	.540
401	1/2"	.622	.843
402	3/4"	.824	1.050
403	1"	1.049	1.312
404	1/4"	.302	.540
405	1/2"	.546	.843
406	3/4"	.742	1.050
407	1"	.957	1.312

FLANGE SIZES AND RATINGS

SIZE	CODE	RATING	CODE	FACING	CODE
3/4"	A	150 LB	U	FLAT FACE	F
1"	B	300 LB	V	RAISED FACE	R
1 1/2"	C	600 LB	W	RING JOINT	J
2"	D	900 LB	X		
2 1/2"	E	1500 LB	Y		
3"	G	2500 LB	Z		
4"	H	OTHER-SPECIFY			
4 1/2"	K				
5"	L				
5 1/2"	M				
6"	N				

**Add "FP" After Flange Facing For Full Penetrant Weld.

**Add "SF" After Flange Facing For Smooth Finish 125-250 RMS.

NOTE-Other Sizes Available. Consult TMS

THERMOWELLS



Socket-Weld

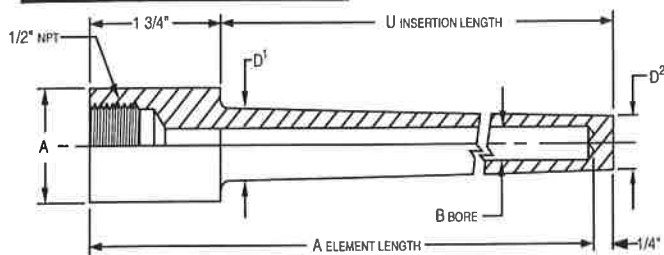

Order Example

501 - R - 7.5 - 4.75

Basic Part No. "T" Length
Material Code From Sec.4, p.9 "U" Insertion Length

PART NO.	PIPE SIZE	"A" DIA.	"B" BORE	"T" LENGTH	D1 DIA.	D2 DIA.
500	3/4"	1.050	.390	1.75	.812	.750
501	3/4"	1.050	.265	1.75	.812	.750
502	1"	1.312	.265	1.75	1.000	.750
503	1"	1.312	.390	1.75	1.000	.750
504	1 1/4"	1.660	.265	1.75	1.000	.750
505	1 1/4"	1.660	.390	1.75	1.000	.750
506	3/4"	1.050	.265	1.75	.812	.812
507	3/4"	1.050	.390	1.75	.812	.812
508	1"	1.312	.265	1.75	1.000	1.000
509	1"	1.312	.390	1.75	1.000	1.000
510	1 1/4"	1.660	.265	1.75	1.000	1.000
511	1 1/4"	1.660	.390	1.75	1.000	1.000

Weld-in, Barstock

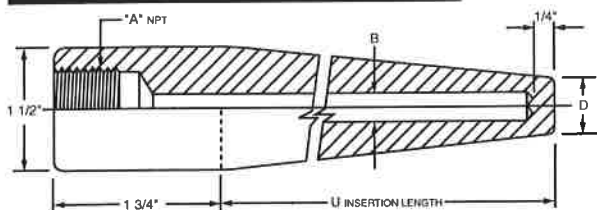

Order Example

603 - P - 12 - 3

Basic Part No. "T" Length + Lag (If Any)
Material Code From Sec.4, p.9 "U" Insertion Length

PART NO.	"A" NPT	"B" BORE	"D" DIA.
600	1/2"	.515	.875
601	1/2"	.437	.875
602	1/2"	.390	.750
603	1/2"	.265	.750

Flanged Barstock

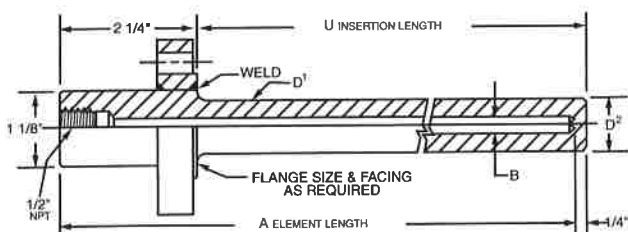

Order Example

705 - R - CYJ - 12 - 4.25

Basic Part No. "T" Length + Lag (If Any)
Material Code From Sec.4, p.9 "U" Insertion Length
Flange Code From Chart

PART NO.	B BORE	D1	D2	FLANGE
700	.515	.937	.937	Specify Flange Size And Rating From Chart
701	.437	.875	.875	
702	.390	.750	.750	
703	.265	.750	.750	
704	.390	.875	.875	
705	.265	.875	.750	
706	.343	1.062	.750	
707	.265	1.062	.625	
708	.390	1.000	.750	
709	.265	1.000	.750	

FLANGE SIZES AND RATINGS

SIZE	CODE	RATING	CODE	FACING	CODE
3/4"	A	150 LB	U	FLAT FACE	F
1"	B	300 LB	V	RAISED FACE	R
1 1/2"	C	600 LB	W	RING JOINT	J
2"	D	900 LB	X		
2 1/2"	E	1500 LB	Y		
3"	G	2500 LB	Z		
4"	H	OTHER-SPECIFY			
4 1/2"	K				
5"	L				
5 1/2"	M				
6"	N				

**Add "FP" After Flange Facing For Full Penetrant Weld.

**Add "SF" After Flange Facing For Smooth Finish 125-250 RMS.

THERMOWELLS



Flanged-Tantalum Sleeve

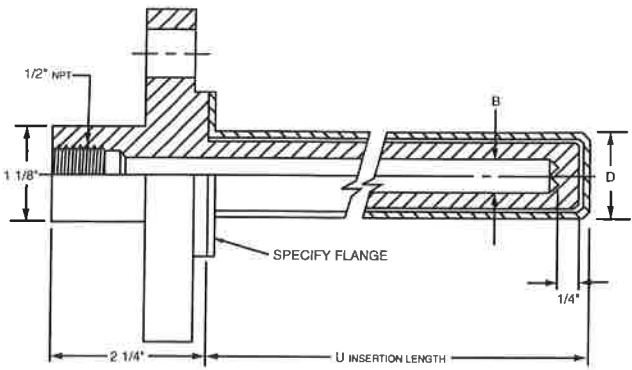

PART NO.	"B" BORE	"D" DIA.	FLANGE
800	.265	.500	Specify From Chart Below.
801	.390	.500	
802	.390	.750	
803	.265	.750	

FLANGE SIZES AND RATINGS

SIZE	CODE	RATING	CODE	FACING	CODE
3/4"	A	150 LB	U	FLAT FACE	F
1"	B	300 LB	V	RAISED FACE	R
1 1/2"	C	600 LB	W	RING JOINT	J
2"	D	900 LB	X		
2 1/2"	E	1500 LB	Y		
3"	G	2500 LB	Z		
4"	H	OTHER-SPECIFY			
4 1/2"	K				
5"	L				
5 1/2"	M				
6"	N				

**Add "FP" After Flange Facing For Full Penetrant Weld.
**Add "SF" After Flange Facing For Smooth Finish 125-250 RMS.

Order Example

800-R-CVR-10-2.25

Basic Part No. Material Code From Sec.4, p.9
"U" Insertion Length
Flange Code From Chart.
"T" Length + Lag (If Any)

Ground Joint

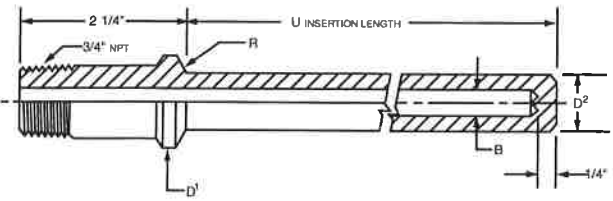

PART NO.	"B" BORE	D ¹ DIA.	D ² DIA.	"R" RADIUS
900	.515	1.375	.875	1.000
901	.390	1.375	.750	1.000
902	.265	1.375	.750	1.000
903	.515	1.750	.875	1.250
904	.390	1.750	.750	1.250

**Shown With O.D. Threads. Internally Threaded Thermowells Are Available. Consult TMS.

Order Example

900-J-12-2.25

Basic Part No. Material Code From Sec.4, p.9
"U" Insertion Length
"T" Length + Lag (If Any)

Van Stone

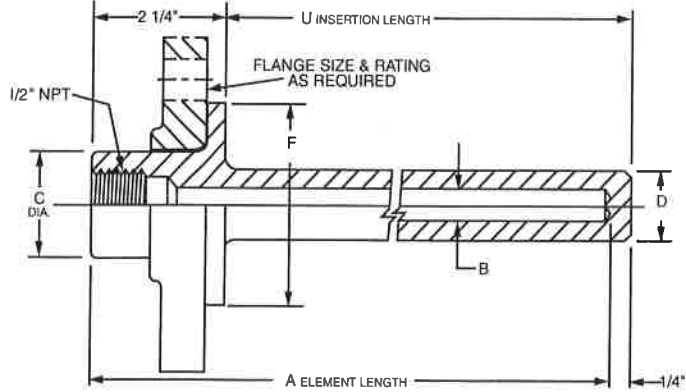

PART NO.	"F" DIA.	"B" BORE	"C" DIA.	"D" DIA.	FLANGE SIZE
1000	2.000	.265	1.312	.750	1"
1001	2.000	.390	1.312	.875	1"
1002	2.875	.265	1.900	.750	1 1/2"
1003	2.875	.390	1.900	.875	1 1/2"

Other Sizes Available. Consult TMS.
Backing Flanges Are Available Upon Request

Order Example

1000-P-12-2.25

Basic Part No. Material Code From Sec.4, p.9
"U" Insertion Length
"T" Length + Lag (If Any)

THERMOWELLS

TMS

Sample Probes

Type 1661

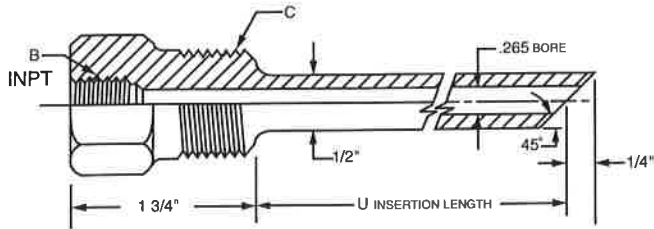

DASH NO.	I NPT	H	C NPT
1	1/4"	7/8"	1/2"
2	1/4"	1 1/8"	3/4"
3	1/4"	1 3/8"	1"
4	1/2"	1 1/8"	1/2"
5	1/2"	1 1/8"	3/4"
6	1/2"	1 3/8"	1"
7	45 DEGREE ANGLE		
8	30 DEGREE ANGLE		
9	NO ANGLE		

** Standard sample probes are machined from drilled barstock and have 45 degree angled tip. Straight tipped sample probes are available. Sample probes are also available from welded tubing in lieu of drilled barstock. Consult TMS.

Type 1662

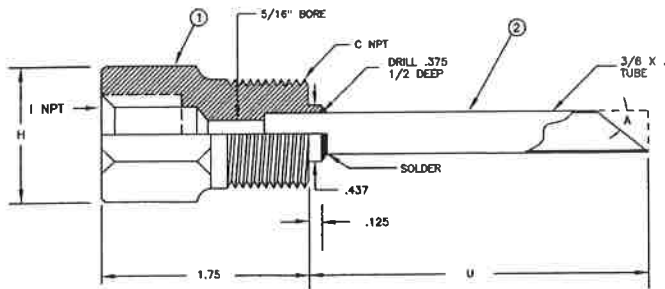

Order Example

1661 - P - 2 - U - A

Part No. ↑ ↑ ↑ ↑ ↑
 Material ↑ ↑ ↑ ↑ ↑ Angle Information
 Dash No. ↑ ↑ ↑ ↑ ↑ Insertion Length

Type 1100-Large Bore For 11/16" Diameter Bulbs

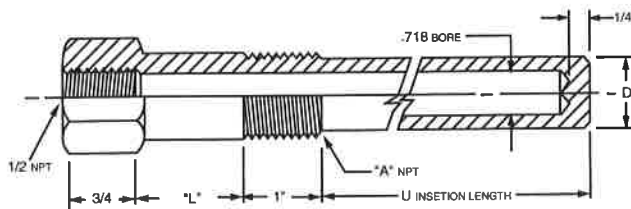

"A" NPT	3/4 NPT or 1 NPT
"U" Length	2", 3", 4", 6", 10", 12"
"D" DIA.	.879 For 3/4 NPT
"D" DIA.	1.100 For 1" NPT

Other Length Available - Consult TMS

Order Example

1100 - 3/4 - 1 - P - 3

Basic Part No. ↑ ↑ ↑ ↑ ↑
 Process Connection ↑ ↑ ↑ ↑ ↑ U Insertion Length
 "L" Lagging Length (For No Lag - Delete Code) ↑ ↑ ↑ ↑ ↑ Material Code From Sec.4, p.9

THERMOWELLS



Ceramic Protection Tubes

Type 1200 - No Bushing

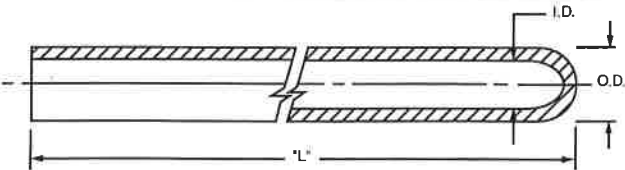

Type 1201 - Hex Nipple

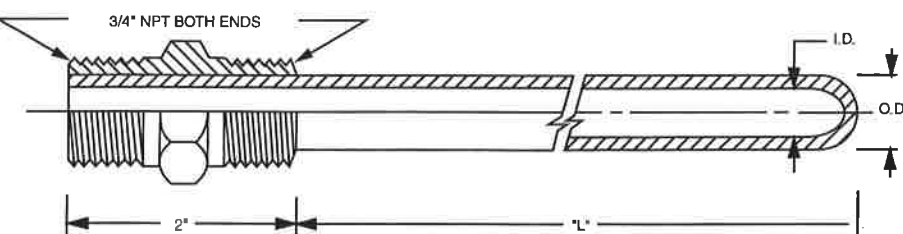

Type 1202 - Standard Nipple

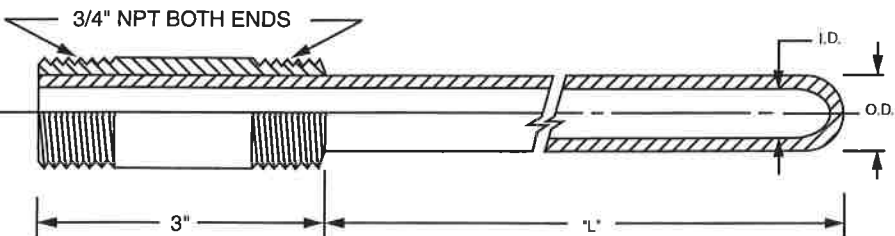

Order Example

12XX - 3 - A - 17

Basic Part No.

Tube Size Code

"L" Length

Material Code

TUBESIZE	I.D.	O.D.
1	.250	.375
2	.375	.500
3	.437	.688

Material: A = Alumina and M= Mullite
Other Sizes And Material Available. Consult TMS.

Protection Tube Materials

MATERIAL	GRADE	MAX. USE TEMP (AIR)	THERMAL SHOCK RESISTANCE	REMARKS
Hexoloy SA	Sintered	3000°F	Excellent	Impermeable at 300°F. maintains strength to 3000 °F excellent corrosion resistance, does not creep, attacked by halides, fused caustics and ferrous metals
Halsic I	Reaction bonded silicon infiltrated	2450°F	Very Good	Extremely good oxidation resistance, corrosion resistant against strong acids and alkalis
Halsic R	Recrystallized SiC	2900°F	Very Good	Reliable bonding of coatings, resistant against strong acids and alkalis
Metal Ceramic	LT1	2500°F	Must be preheated to 900 °F before immersion into molten metals at 2000 °F Temp. or above	Not recommended in carburizing, Nitrogen atmospheres, high vacuum or in molten Aluminum
Alumina	99.7%	3100°F	Fair preheating rrecommended	Creeps at 2900°F
Mullite		3100°F	Poor must be preheated to 900 °F	Non-Ferrous Metals

THERMOMETER WELLS



Threaded Bimetal Thermometer Wells

Type T100 For 2.5" Stem Thermometers

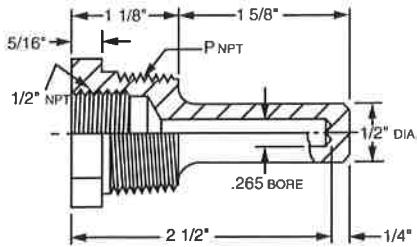

Type T101 For 4" Stem Thermometers

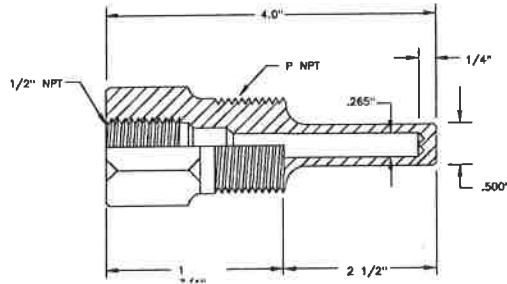

Type T102 With 2" Lag For 6" Stem Thermometers

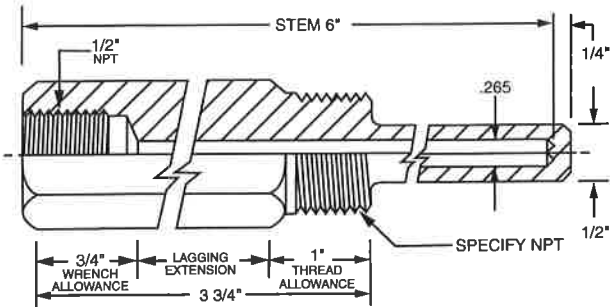

Type T103 For 6" And Longer Stem Thermometers

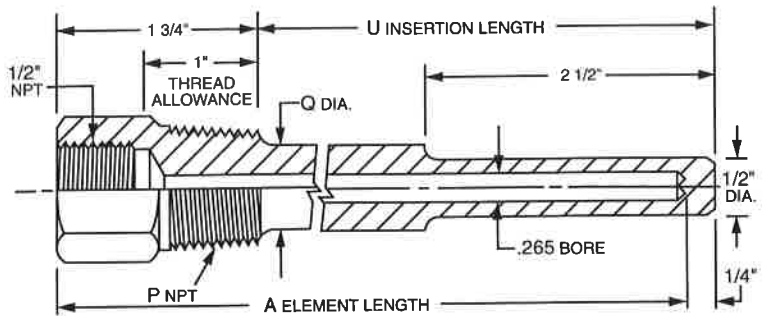

Type T104 With 3" Lag For 9" And Longer Bimetal Thermometers

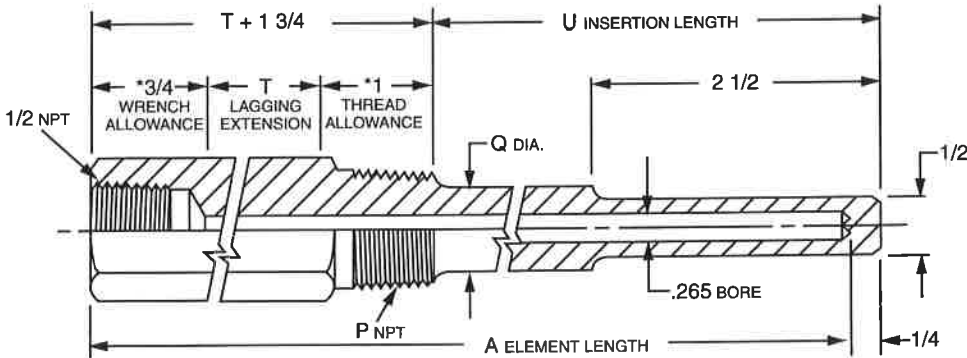

"P" PROCESS CONNECTION	"Q" SHANK DIA.
1/2"	.625
3/4"	.750
1"	.875

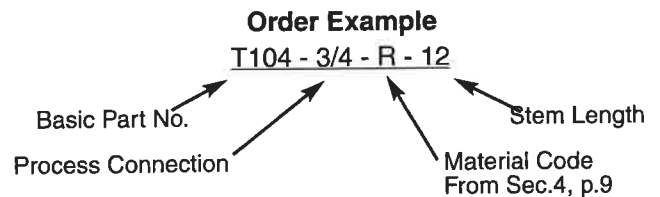

****Note:** Thermowells for 2 1/2" stem length with 1/2" NPT Process Connections will have a "U" length of 1 1/2" in order to accommodate 1/2" internal and 1/2" external threads.

THERMOMETER WELLS



Flanged Thermowells For Bimetal Thermometers

Type T200

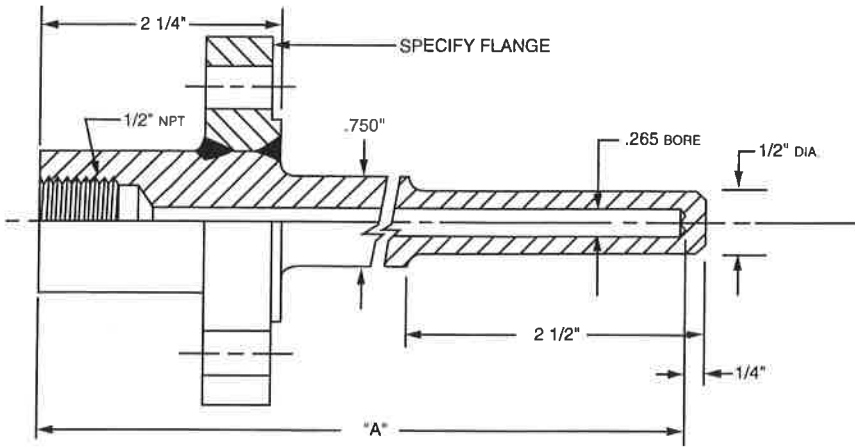

FLANGE SIZES AND RATINGS

SIZE	CODE	RATING	CODE	FACING	CODE
3/4"	A	150 LB	U	FLAT FACE	F
1"	B	300 LB	V	RAISED FACE	R
1 1/2"	C	600 LB	W	RING JOINT	J
2"	D	900 LB	X		
2 1/2"	E	1500 LB	Y		
3"	G	2500 LB	Z		
4"	H	OTHER-SPECIFY			
4 1/2"	K				
5"	L				
5 1/2"	M				
6"	N				

**Add "FP" After Flange Facing For Full Penetrant Weld.

**Add "SF" After Flange Facing For Smooth Finish 125-250 RMS.

Order Example

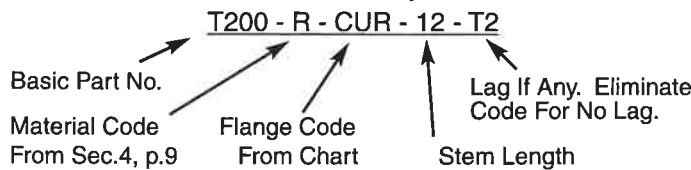

Socket Weld Thermowells For Bimetal Thermometers

Type T700

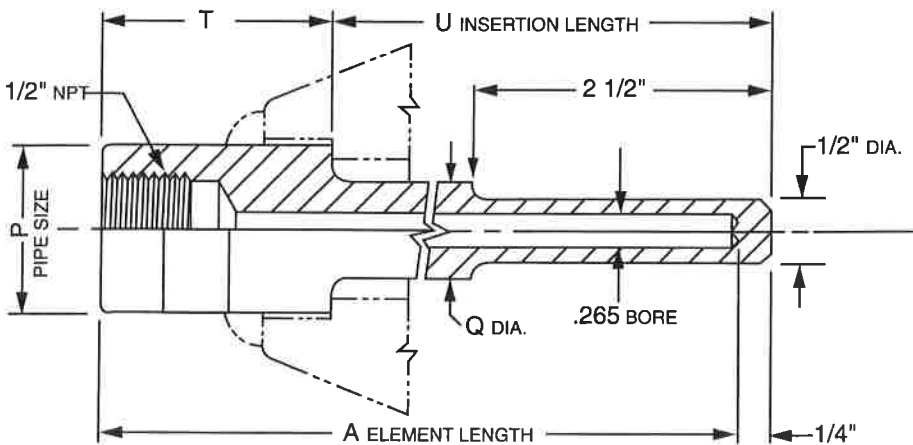

Order Example

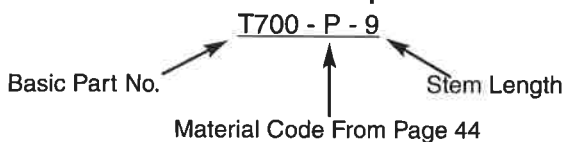

PART NO.	PIPE SIZE	"P" DIM.	"T" LENGTH	"Q" DIA.**
T700	3/4"	1.050	1.75	.750
T701	1"	1.312	1.75	.875

THERMOWELLS

TMS

Plugs And Chains

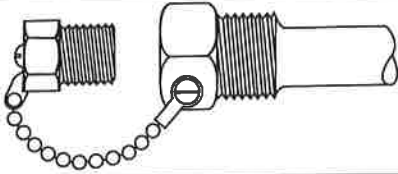

Plug and Chains are available for internal threaded Thermowells. Standard materials are brass and stainless steel. To order specify the code for material desired at the end of Thermowell part number. BP - Brass Plug and Chain. SP - Stainless Plug and Chain

Material Codes

MATERIAL	CODE	MATERIAL	CODE
304S/S	P	Incoloy 800	F
316S/S	R	Inconel 600	J
310S/S	Q	Monel 400	L
321S/S	U	Monel 500	M
347S/S	D	Nickel 200	N
304LS/S	E	F11	A
316LS/S	G	F22	B
410S/S	V	Carbon Steel	CS
446S/S	Y	A-105	T
Alloy 20	C	Brass	BR
HR160	W	Titanium	TI
Hastelloy B	HB	Other (Specify)	X
Hastelloy C	HC		

***Material selection is critical to the life of the Thermowell. Corrosion and temperatures are major deciding factors in the selection of materials suitable for a particular application. Recommended materials are given in the "Material Selection Guide". If further assistance is needed, please consult TMS. Our sales staff will assist you in which materials may be suitable for your particular application.

Material Specifications

This chart will serve as a guide for selection of Thermowell materials. There are instances where special conditions exist and therefore, special applications should be submitted to "TMS" for recommendations.

Media	Temp. F.	Conc.	Recom. Material	Media	Temp. F.	Conc.	Recom. Material
Acetic Acid	212	All	Monel	Fatty Acids	500	All	316SS
Acetic Anhydride	300		Nickel	Ferric Chloride	75	All	Hast. C
Acetone	212	All	304SS	Ferric Sulfate	300	All	304SS
Acetylene	400		304SS	Formaldehyde	212	40%	316SS
Alcohols	212	All	304SS	Formic Acid	300	All	316SS
Alum (Potassium or Sodium)	300	All	Hast. C	Freon	300		Steel
Aluminum Chloride	212	All	Hast. B	Fluorine, Anhydrous	100		304SS
Aluminum Sulfate	212	All	316SS	Furfural	450		316SS
Ammonia, Dry	212	All	304SS/316SS	Gasoline	300		Steel
Ammonium Hydroxide	212	All	304SS/316SS	Glucose	300		304SS
Ammonium Chloride	300	50%	Monel	Glue PH 6-8	300	All	304SS
Ammonium Nitrate	300	All	304SS	Glycerine	212	All	Brass
Ammonium Sulphate	212	All	316SS	Hydrobromic Acid	212	All	Hast. C
Amyl Acetate	300	All	Monel	Hydrochloric Acid (37 - 38%)	225	All	Hast. B.
Aniline	75		304SS	Hydrogen Chloride, Dry	500		304SS
Asphalt	250		304SS	Hydrocyanic Acid	212	All	304SS
Barium Compounds (See Calcium)				Hydrofluoric Acid	212	60%	Monel
Beer	70		304SS	Hydrogen Flouride, Dry	175		Steel
Benzene	70		Steel	Hydrofluogilic Acid	212	40%	Monel
Benzoic Acid	212	All	316SS	Hydrogen Peroxide	125	10 - 100%	304SS
Bleaching Powder	70	15%	Monel	Kerosene	300	All	Steel
Borax	212	All	Brass	Lacquers & Thinners	300	All	304SS
Bordeaux Mixture	200		304SS	Lactic Acid	300	All	316SS
Boric Acid	400	All	316SS	Lime	212	All	316SS
Bromine	125	Dry	Monel	Linseed Oil	75		Steel
Butane	400	All	Steel	Magnesium Chloride	212	50%	Nickel
Butyl Alcohol (See Alcohol)				Magnesium Hydroxide (Or Oxide)	75	All	304SS
Butyric Acid	212		Hast. C	Magnesium Sulfate	212	40%	304SS
Calcium Bisulphite	75	All	Hast. C	Mercuric Chloride	75	10%	Hast. C
Calcium Chloride	212	All	Hast. C	Mercury	700	100%	Steel
Calcium Hydroxide	300	20%	Hast. C	Methylene	212	All	304SS
Calcium Hypochlorite (See Bleaching Powder)				Methyl Chloride, Dry	75		Steel
Carbolic Acid (See Phenol)				Milk, Fresh Or Sour	180		304SS
Carbon Dioxide, Dry	800	All	Brass	Molasses (See Glucose)			
Carbonated Water	212	All	304SS	Natural Gas	70		304SS
Carbonated Beverages	212		304SS	Nitric Acid	75	All	304SS
Carbon Disulfide	200		304SS	Nitric Acid	110	All	316SS
Carbon Tetrachloride	125	All	Monel	Oxygen	75	All	Steel
Chlorine, Dry	100		Monel	Oleic Acid (See Fatty Acid)	212	All	Monel
Chlorine, Moist	100	All	Monel	Oxalic Acid			
Chloroacetic Acid	212	All	Monel	Photographic Bleaching	100	All	304SS
Chloroform, Dry	212		Monel	Palmitic Acid (See Fatty Acid)			
Chromic Acid	300	All	Hast. C	Phosphoric Acid	212	All	316SS
Cider	300	All	304SS	Phenol	212	All	316SS
Citric Acid	212	All	Hast. C	Potassium Compounds (See Sodium Compounds)			
Copper (10) Chloride	212	All	Hast. C	Propane	300		Steel
Copper (10) Nitrate	300	All	316SS	Rosin	700	100%	316SS
Copper (10) Sulfate	300	All	316SS	Sea Water	75		Monel
Copper Plating Solution (Cyanide)	180		304SS	Soap & Detergents	212	All	304SS
Copper Plating Solution (Acid)	75		304SS	Sodium Bicarbonate	212	20%	316SS
Corn Oil	200		304SS	Sodium Bisulphite	212	20%	316SS
Creosote	200	All	304SS	Sodium Bisulphate	212	20%	304SS
Crude Oil	300		Monel	Sodium Carbinatate	212	40%	316SS
Ethyl Acetate (See Lacqre Thinner)				Sodium Chloride	300	30%	Monel
Ethyl Chloride, Dry	500		Steel	Sodium Chromate	212	All	316SS
Ethanol (See Alcohol)				Salt Or Brine (See Sodium Chloride)			
Ethylene Glycol (Uninhibited)	212	All	304SS	Sodium Cyanide	212	All	304SS
Ethylene Oxide	75		Steel	Sodium Hydroxide	212	30%	316SS
				Sodium Hypochlorite	75	10%	Hast. C
				Sodium Nitrate	212	40%	304SS

THERMOWELLS

TMS

Media	Temp. F.	Conc.	Recom. Material	Media	Temp. F.	Conc.	Recom. Material
Sodium Nitrate	75	20%	316SS	Sulphuric Acid	212	10%	316SS
Sodium Phosphate	212	10%	Steel	Sulphuric Acid	212	10%-90%	Hast. B
Sodium Silicate	212	10%	Steel	Sulphuric Acid	212	90 - 100%	Hast. B
Sodium Sulfate	212	30%	316SS	Sulphuric Acid, Fuming	175		Alloy 20
Sodium Sulfide	212	10%	316SS	Sulfurous Acid	75	20%	316SS
Sodium Sulfide	212	30%	304SS	Titanium Tetrachloride	75	All	316SS
Sodium Sulfite	212	30%	304SS	Tannic Acid	75	40%	Hast. B
Sodium Thiosulfate	212	All	304SS	Toluene	75		Steel
Steam				Trichloroacetic Acid	75	All	Hast. B
Stearic Acid	(See Fatty Acid)			Trichlorethylene	300	Dry	Monel
Sugar Solution	(See Glucose)			Turpentine	75		316SS
Sulphur	500		304SS	Varnish	150		Steel
Sulfur Chloride	75	Dry	316SS	Zinc Chloride	212	All	Hast. B
Sulfur Dioxide	500	Dry	316SS	Zinc Sulfate	212	All	316SS
Sulfur Trioxide	500	Dry	316SS				

Specialty Thermowells

The following Thermowells while not shown in this catalog are available upon request. Consult TMS for part numbers and pricing on these items.

- Sanitary Thermowells
- Navy Class Thermowells
- Industrial Thermometer Wells
- Thermowells For Lab Type Thermometers
- Test Thermowells

Services

The following services are available. Consult TMS for information and pricing on these services:

- Coatings - Teflon, Kynar and other materials are available for Thermowell Coatings.
- Hard Facings - Hard Facings such as Stellite are available for abrasive services.
- Hydrostatic Testing - TMS can Hydrostatic Test your Thermowells on site.
- Dye Penetrant Testing - Dye Penetrant Testing of weld joints.
- Velocity Calculations - Velocity Calculations performed to ASME PTC 19.3 specifications.
- Special Machine Shop Services - TMS can provide special machine shop services per your drawings.

Technical Information

In many temperature measurement applications, the temperature element cannot be placed directly into the media it is to measure. In these instances a thermowell must be used to protect the temperature element.

MATERIALS

The materials selected for service is governed by the environment the thermowell will be subject to. Corrosion resistance is one of the major concerns in regard to material selection for a particular application.

CONNECTIONS

Connections on the thermowell to the process may be made in any manner approved by the ASME Boiler and Pressure Vessel Piping Code.

INSERTION LENGTH

The insertion length should be long enough to allow the total temperature sensitive portion of the element to project into the media to be measured.

A thermometer bulb should be placed into liquid an amount equivalent to the bulbs sensitive length plus a minimum of one inch. In gas or air, the bulb should be placed a minimum of three inches plus the bulbs sensitive length.

Thermocouples have short temperature sensitive lengths and can be used with the smallest of insertion lengths.

Bimetal thermometers, RTD elements and liquid-in-glass thermometers have sensitive lengths of approximately one to two inches.

Filled system thermometers have various sensitive lengths. The sensitive length must be determined before deciding on the proper insertion length.

Be sure to take into account any fittings or walls that must be passed through when deciding on the proper insertion length for the thermowell.

BORE SIZE

Be sure to select a bore diameter compatible with the element being used.

DESIGN (Pressure and Velocity Ratings)

The factors required to provide increased thermowell strength reduces the accuracy and response time of temperature elements. Thermowell designs must carefully balance all factors so that accuracy effect is kept at a minimum while maintaining adequate strength.

ASME PTC19.3 offers procedures and guidelines in determining whether a particular thermowell will be suitable for a particular application.

Thermowell failure is caused by vibration, pressure and steady state flow. Separate evaluations are required to determine the suitability for any application in question. Failures are not normally due to pressure or temperature. Calculations are necessary in choosing proper diameters (wall thickness) and materials for a given application.

Vibrational effects are more likely to cause thermowell failure. Fluid flowing by the thermowell forms what is known as the Von Karman Trail. This is a turbulent wake that has a frequency based on the diameter of the thermowell and the velocity of the fluid or media. The thermowell must have sufficient stiffness so that the wake frequency will never equal the natural frequency of the thermowell. If the natural frequency and the wake frequency becomes equal, the thermowell will vibrate to destruction. Calculations can be utilized to determine if a thermowell is acceptable under given conditions for a particular service.

The sales staff at TMS is capable of offering assistance in selecting materials and/or thermowells for a given service. Suggestions can be offered based on information about the particular application.

Warranty

Temperature Measurement Systems (TMS) warrants its products to be free from defects in materials and workmanship. We are pleased to offer suggestions on the use of products; however, we assume no responsibility for any errors and/or omissions. We assume no liability for any damages resulting from use of suggested products.

Temperature Measurement Systems (TMS) makes no warranties or representations of any kind whatsoever, expressed or implied, except that of title. All implied warranties including any warranty for merchantability and fitness for a particular purpose are hereby disclaimed.

The remedies of the purchaser set forth herein are exclusive and the total liability of Temperature Measurement Systems (TMS) whether based on contract, warranty, negligence, indemnification, strict liability or otherwise shall not exceed the purchase price of the component upon which liability is based. Temperature Measurement Systems (TMS) sole responsibility will be to replace the material found defective in workmanship and/or material. In no event shall Temperature Measurement Systems (TMS) be liable for any damages or losses, whether direct, indirect, incidental, special or consequential. Warranty is limited to the purchaser only and cannot be transferred to third parties.

Materials furnished by Temperature Measurement Systems (TMS) is not intended for use in any nuclear installation or activity or in medical applications or used on humans. Should any product be used in or with any of the above or misused in any way, Temperature Measurement Systems (TMS) assumes no responsibility as set forth in the above warranty disclaimer. Purchaser will hold Temperature Measurement Systems (TMS) harmless from any liability or damage whatsoever arising out of the use of products in any of these manners.

Materials are warranted for 12 months from startup or 24 months from shipment date.

SECTION 5

WIRE

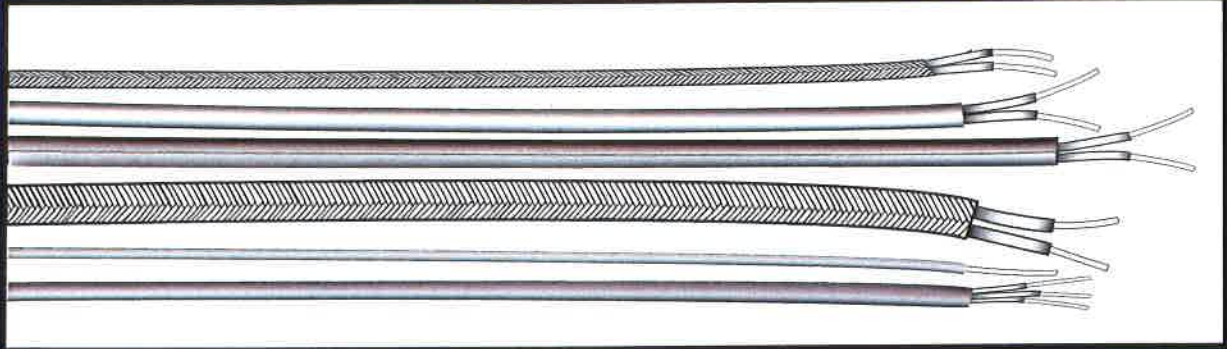

WIRE INDEX - SECTION 5

Technical Information – Thermocouple Wire.....	1-4
Thermocouple Wire and Multipair Cable – Insulation Specifications	5-6
Standard Constructions	7-8
Extension Grade TC Wire-Standard Constructions	9-11
RTD Wire-Construction Characteristics	11
RTD Wire-Standard Constructions and Ordering Information	12

Technical Information

Thermocouple wire and thermocouple extension wire is normally ordered and specified by ANSI letter designations for wire. Positive and negative legs are identified by suffixes P (positive) and N (negative).

ANSI LETTER	LEGS-POSITIVE AND NEGATIVE	TRADE NAMES
B	BP BN	Platinum 30% Rhodium Platinum 6% Rhodium
C**	CP CN	W5Re (Tungsten 5% Rhenium) W2Re (Tungsten 26% Rhenium)
E	EP EN	Chromel*, Tophel*, Hai-Kp* Constantan, Cupron*, Advance*
J	JP JN	Iron Constantan, Cupron*, Advance*
K	KP KN	Chromel*, Tophel*, Hai-Kp* Alumel*, Nial*, Hai-Kn*
N	NP NN	Nicrosil Nisil
R	RP RN	Platinum 13% Rhodium Pure Platinum
S	SP SN	Platinum 10% Rhodium Pure Platinum
T	TP TN	Copper Constantan, Cupron*, Advance*

**Not an ANSI symbol

*Cupron, NIAL and Tophel are registered trademarks of Carpenter Technology.

*Advance, HAI-KP and HAI-KN are registered trademarks of Harrison Alloys Co.

*Chromel and Alumel are registered trademarks of Hoskins Manufacturing Co.

Tolerances

Unless otherwise specified, all thermocouple wire and extension wire is supplied to meet tolerances for standard limits and special limits of error as per ANSI MC96.1. The standard and special tolerances for thermocouple and extension wire is given in the following tables. Where tolerances are given in percentages, the percentage applies to the temperature being measured.

Initial Calibration Tolerances for Wire and Cable

Reference Junction 32 Deg. F (0 Deg. C)

CALIBRATION	TEMPERATURE RANGE		TOLERANCES (WHICHEVER IS GREATER)	
	DEG. F	DEG. C	STANDARD	SPECIAL
Thermocouple Grade Wire				
B	1598 to 3092	870 to 1700	+/- 0.5%	
E	32 to 1652	0 to 900	+/-1.7 C or +/-0.5%	+/-1.0 C or +/-0.4%
J	32 to 1382	0 to 750	+/-2.2 C or +/-0.75%	+/-1.1 C or +/-0.4%
K	32 to 2282	0 to 1250	+/-2.2 C or +/-0.75%	+/-1.1 C or +/-0.4%
N	32 to 2282	0 to 1250	+/-2.2 C or +/-0.75%	+/-1.1 C or +/-0.4%
R or S	32 to 2642	0 to 1450	+/-1.5 C or +/-0.25%	+/-0.6 C or +/-0.1%
T	32 to 662	70 to 350	+/-1.0 C or +/-0.75%	+/-0.5 C or +/-0.4%
Extension Grade Wire				
EX	32 to 392	0 to 200	+/-1.7 C	+/-1.0 C
JX	32 to 392	0 to 200	+/-2.2 C	+/-1.1 C
KX	32 to 392	0 to 200	+/-2.2 C	+/-1.1 C
NX	32 to 392	0 to 200	+/-2.2 C	+/-1.1 C
TX	32 to 212	0 to 100	+/-1.0 C	+/-0.5 C
Compensating Extension Wire				
BX*	32 to 392 +	0 to 200	+/-3.7 C	
CX**	32 to 1600 +	0 to 870	+/-6.8 C	
RX, SX***	32 to 392 +	0 to 200	+/-5.0 C	
Cryogenic Range Wire				
E****	-328 to 32	-200 to 0	+/-1.7 C or +/- 1%	++
K****	-328 to 32	-200 to 0	+/-2.2 C or +/- 2%	++
T****	-328 to 32	-200 to 0	+/-1.0 C or +/- 1.5%	++

See Notes Following Page.

Notes

- * Copper vs. Copper compensating extension wire-maximum temperature of 212°F, with maximum deviations shown but with no significant deviation over 32°F to 122°F range. Matched compensating wire is available for use over the range of 32°F to 392°F with tolerances of +/-0.033mV (+/-3.7 C ++).
- ** Not an ANSI Symbol
- *** Copper (+) Versus copper nickel alloy (-).
- **** Thermocouple materials are normally supplied to meet tolerances specified in the table for the normal specified range. The same materials may not fall within the cryogenic tolerances in the second section of the table. If materials are required to meet the cryogenic tolerances, the specifications must indicate this. Selection of materials usually will be required. Tolerances shown in the table are not necessarily an indication of the accuracy of measurements in use after initial heating of the material.
- ++ Information is limited that would justify establishing special tolerances for cryogenic temperatures. Experience suggests the following tolerances for Type E and T thermocouples:

Type E -200 to 0°C +/-0.0°C or 0.5% (whichever is greater)
 Type T -200 to 0°C +/-0.5°C or +/-0.8% (whichever is greater)

These tolerances are given only as a guide for discussion. Due to the characteristics of the material, cryogenic tolerances for Type J thermocouples and special cryogenic tolerances for Type K thermocouples are not listed.

+ Type B, C, R, and S thermocouple alloys possess non-linear temperature-EMF curves. Because of this non-linearity, the error introduced into a thermocouple system by the compensating wire will be variable when expressed in degrees. The degree C tolerances given are based on the following measuring junction temperatures:

Wire Type	Measuring Junction Temperature
BX	Greater than 1832°F (1000°C)
SX	Greater than 1598°F (870°C)

ANSI Color Codes As Per MC96.1

CONDUCTORS/ JACKET	EXT. OR T/C GRADE	TYPE B	TYPE E	TYPE J	TYPE K	TYPE N	TYPE R	TYPE S	TYPE T
Jacket Positive Leg Negative Leg	T/C Grade	None None None	Brown Purple Red	Brown White Red	Brown Yellow Red	Brown Orange Red	None None None	None None None	Brown Blue Red
Jacket Positive Leg Negative Leg	Ext. Grade	Gray Gray Red	Purple Purple Red	Black White Red	Yellow Yellow Red	Orange Orange Red	Green Black Red	Green Black Red	Blue Blue Red

Solid And Stranded Conductors

Thermocouple wire and extension wire is normally supplied with solid conductors; however, when greater flexibility is required, stranded wire is available. Stranded wire is recommended when flexibility is a major concern.

Conductor Sizes

B & S WIRE GAUGE	SOLID CONDUCTOR	STRANDED CONDUCTOR		
	DIAMETER	DIAMETER	NUMBER OF STRANDS	STRAND GAUGE
14	0.064"	0.076"	7	22
16	0.051"	0.060"	7	24
20	0.032"	0.038"	7	28
24	0.020"	0.024"	7	32

Long Leadwire For Thermocouples

Long leadwire runs make conductor resistance an important consideration in the selection of the wire gauge suitable for the particular application. The table below shows the minimal ohms per double foot for thermocouple grade and extension wire. Ohms per double foot is the total resistance in ohms for both conductors per foot.

Nominal Resistance/Ohms Per Double Foot @ 20 Deg. C

B & S GAUGE	DIA.	BX	CX*	E	J	K	N	RX/SX	T
14	0.064	0.024	0.093	0.177	0.091	0.147	0.195	0.010	0.048
16	0.051	0.039	0.147	0.281	0.145	0.233	0.3310	0.016	0.120
20	0.032	0.098	0.372	0.709	0.367	0.589	0.783	0.040	0.304
24	0.020	0.248	0.941	1.795	0.928	1.490	1.980	1.100	0.768
14 Stranded	0.076	0.022	0.085	0.161	0.083	0.134	0.178	0.009	0.069
16 Stranded	0.060	0.035	0.134	0.256	0.133	0.213	0.283	0.014	0.110
20 Stranded	0.038	0.090	0.340	0.648	0.335	0.538	0.715	0.036	0.277
24 Stranded	0.024	0.227	0.859	1.639	0.848	1.361	1.808	0.091	0.701

Thermocouple Grade And Extension Wire Selection

There are profound differences in thermocouple grade wire and extension grade wire. Thermocouple grade wire is used to actually measure temperature where extension grade wire is used to carry the millivolt signal to the instrumentation.

Thermocouple extension grade wire is calibrated to a maximum temperature of 400 degrees F. The insulations used on some extension grade wire has temperature ratings above this 400 degree F range. This is to allow the wire to survive in the event it comes into contact with furnace walls and/or parts above this 400 degree F temperature.

Wire constructions are rated for continuous service as well as for single reading applications. The continuous service is the highest temperature at which the particular insulation will survive indefinitely. The single reading temperature has been determined by actual testing of the wire. Each insulation will perform differently when exposed to the single reading temperature rating. Normally, the wire will produce accurate readings at the maximum single reading temperature; however, the wire will become less flexible and abrasion resistant.

Recommended Upper Temperature Limits For B & S Wire Gauges

T/C TYPE	8 GAUGE	14 GAUGE	20 GAUGE	24 GAUGE
E	1600 Deg. F	1200 Deg. F	1005 Deg. F	805 Deg. F
J	1400 Deg. F	1085 Deg. F	895 Deg. F	700 Deg. F
K	2300 Deg. F	1995 Deg. F	1795 Deg. F	1600 Deg. F
N	2300 Deg. F	1995 Deg. F	1795 Deg. F	1600 Deg. F
T	-----	700 Deg. F	500 Deg. F	395 Deg. F

Insulated Thermocouple Wire

Insulation Specifications

CODE	SINGLE CONDUCTOR		DUPLEX CONDUCTORS		TEMPERATURE RATING		ANSI COLOR CODED	PHYSICAL CHARACTERISTICS			NOTES
	INSULATION	IMPREGNATION	INSULATION	IMPREGNATION	CONTINUOUS	SINGLE READING		ABRASION RESISTANCE	MOISTURE RESISTANCE	CHEMICAL RESISTANCE	
01	Vitreous Silica Fiber	None	Vitreous Silica Fiber	None	1600 F	2000 F	No	Fair	Fair	Fair	
02	Double Glass Braid	Modified Resin	Glass Braid	Modified Resin	900 F	1000 F	Yes	Good	Good	Good	1
03	Enamel/ Glass Braid	Modified Resin	Glass Braid	Modified Resin	900 F	1000 F	Yes	Fair	Good	Good	1
04	Glass Braid	Modified Resin	Glass Braid	Modified Resin	900 F	1000 F	Yes	Fair	Good	Good	1
05	Double Glass Wrap	Modified Resin	Glass Braid	Modified Resin	900 F	1000 F	Yes	Fair	Good	Good	1
06	Glass Braid	None	Glass Braid	None	900 F	1000 F	No	Fair	Fair	Good	
07	High Temp. Glass Braid	None	High Temp. Glass Braid	Modified Resin	1300 F	1600 F	Tracer	Good	Fair	Good	1
08	High Temp. Glass Braid	None	High Temp. Glass Braid	Light Lacquer Coating	1300 F	1600 F	Both Legs	Fair	Fair	Good	2
09	Glass Braid	Modified Resin	Glass Braid	Modified Resin	900 F	1000 F	No	Good	Good	Good	1
10	High Temp. Glass Braid	High Temp. Varnish	Twisted	N/A	1300 F	1600 F	Yes	Good	Good	Good	1
11	Glass Braid	Modified	Twisted	N/A	900 F	1000 F	Yes	Good	Good	Good	1
12	High Temp. Glass Braid	High Temp. Varnish	High Temp. Glass Braid	High Temp. Varnish	1300 F	1600 F	Yes	Good	Good	Good	
13	Ceramic Fiber	None	Ceramic Fiber	None	2200 F	2600 F	No	Good	Fair	Good	
14	Polivinyli	None	Polyvinyl	None	221 F	221 F	Yes	Good	Excellent	Good	
15	Nylon	None	Nylon	None	300 F	300 F	Yes	Excellent	Fair	Good	
16	Polyvinyl	None	Ripcord	None	221 F	221 F	Yes	Good	Excellent	Good	
17	Extruded FEP	None	Extruded FEP	None	400 F	500 F	Yes	Excellent	Excellent	Excellent	
18	Fused TFE Tape	None	Fused TFE Tape	None	500 F	600 F	Yes	Good	Excellent	Excellent	
19	Extuded FEP	None	Extruded FEP Twisted	None	400 F	500 F	Yes	Excellent	Excellent	Excellent	3
20	Polyvinyl	None	Polyvinyl Twisted	None	221 F	221 F	Yes	Good	Excellent	Excellent	3
21	Fused Kapton	None	Fused Kapton	None	600 F	600 F	Yes	Excellent	Excellent	Excellent	4
22	PFA	None	PFA	None	500 F	550 F	Yes	Good	Excellent	Excellent	
23	PFA	None	PFA Twisted	None	500 F	550 F	Yes	Good	Excellent	Good	3
24	TFE Tape Coated Fiberglass	None	TFE Coated Glass Braid	None	900 F	1000 F	Yes	Good	Excellent	Excellent	5
25	Ceramic Fiber	None	Ceramic Fiber	None	2200 F	2600 F	No	Good	Fair	Good	

NOTE 1: Impregnation Maintained to 400°F.

NOTE 2: Coating Maintained to 400°F.

NOTE 3: Aluminum Polyester Shield With Drain Wire.

NOTE 4: FEP Binder Melts @ 500°F.

NOTE 5: TFE Good to 500°F

Insulated Thermocouple Multipair Cable

CODE	SINGLE CONDUCTOR		DUPLEX CONDUCTOR		TEMPERATURE RATING		ANSI COLOR CODED	PHYSICAL CHARACTERISTICS			NOTES
	INSULATION	IMPREGNATION	INSULATION	IMPREGNATION	CONTINUOUS	SINGLE READING		ABRASION RESISTANCE	MOISTURE RESISTANCE	CHEMICAL RESISTANCE	
40	Polyvinyl	None	Polyvinyl	None	221 F	221 F	Yes	Good	Excellent	Excellent	Overall Aluminum/Polyester shield with drain wire.
41	Polyvinyl	None	Polyvinyl	None	221 F	221 F	Yes	Good	Excellent	Excellent	Each pair shielded & overall shielded with Aluminum/Polyester with drain.

**Special constructions Are Available. Consult TMS.

Thermocouple Wire Ordering Information:

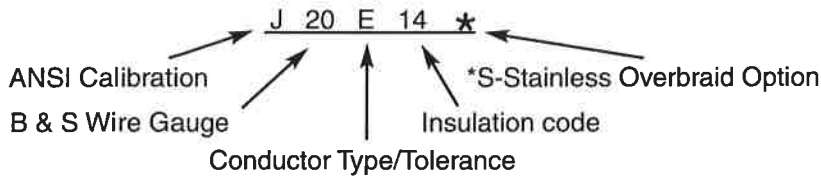

- A - Thermocouple Grade, Solid Conductors, Standard Tolerance
- B - Thermocouple Grade, Solid Conductors, Special Tolerance
- C - Thermocouple Grade, Stranded Conductors, Standard Tolerance
- D - Thermocouple Grade, Stranded Conductors, Special Tolerance
- E - Extension Grade, Solid Conductors, Standard Tolerance
- F - Extension Grade, Solid Conductors, Special Tolerance
- G - Extension Grade, Stranded Conductors, Standard Tolerance
- H - Extension Grade, Stranded Conductors, Special Tolerance

*Other overbraid materials are available on request. Consult TMS.

Multipair Cable Ordering Information:

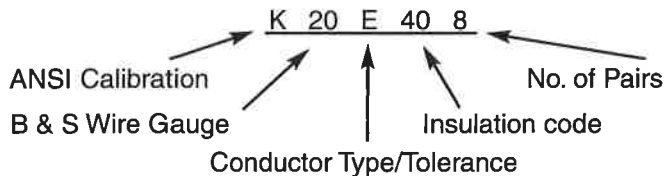

- E - Extension Grade, Solid Conductors, Standard Tolerance
- F - Extension Grade, Solid Conductors, Special Tolerance

Standard Construction - Thermocouple Grade

PART NUMBER	B & S WIRE GAUGE	CONDUCTOR DIAMETER	LBS. PER 1000 FT.	T/C OR EXT. GRADE/ CONDUCTOR TYPE	OVERBRAID AVAILABLE
E20A04	20	0.032"	9 Lbs/M	Thermocouple Solid	Yes
E20B04	20	0.032	9 Lbs/M	Thermocouple Solid	Yes
E20A12	20	0.032	13 Lbs/M	Thermocouple Solid	Yes
E20A18	20	0.032	11 Lbs/M	Thermocouple Solid	Yes
E20A22	20	0.032	12 Lbs/M	Thermocouple Solid	Yes
E20A23	20	0.032	18 Lbs/M	Thermocouple Solid	Yes
J14A07	14	0.064	36 Lbs/M	Thermocouple Solid	Yes
J14B07	14	0.064	36 Lbs/M	Thermocouple Solid	Yes
J16A09	16	0.051	22 Lbs/M	Thermocouple Solid	Yes
J16A17	16	0.051	28 Lbs/M	Thermocouple Solid	Yes
J20A04	20	0.032	9 Lbs/M	Thermocouple Solid	Yes
J20B04	20	0.032	9 Lbs/M	Thermocouple Solid	Yes
J20A05	20	0.032	6 Lbs/M	Thermocouple Solid	Yes
J20B05	20	0.032	6 Lbs/M	Thermocouple Solid	Yes
J20A10	20	0.032	10 Lbs/M	Thermocouple Solid	Yes
J20B10	20	0.032	10 Lbs/M	Thermocouple Solid	Yes
J20A11	20	0.032	10 Lbs/M	Thermocouple Solid	Yes
J20B11	20	0.032	10 Lbs/M	Thermocouple Solid	Yes
J20A12	20	0.032	13 Lbs/M	Thermocouple Solid	Yes
J20B12	20	0.032	13 Lbs/M	Thermocouple Solid	Yes
J20A17	20	0.032	12 Lbs/M	Thermocouple Solid	Yes
J20B17	20	0.032	12 Lbs/M	Thermocouple Solid	Yes
J20A18	20	0.032	11 Lbs/M	Thermocouple Solid	Yes
J20B18	20	0.032	11 Lbs/M	Thermocouple Solid	Yes
J20A19	20	0.032	18 Lbs/M	Thermocouple Solid	Yes
J20B19	20	0.032	18 Lbs/M	Thermocouple Solid	Yes
J20A22	20	0.032	12 Lbs/M	Thermocouple Solid	Yes
J20A23	20	0.032	18 Lbs/M	Thermocouple Solid	Yes
J20C02	20 (7/28)	0.038	10 Lbs/M	Thermocouple Stranded	Yes
J20C17	20 (7/28)	0.038	12 Lbs/M	Thermocouple Stranded	Yes
K14A07	14	0.064	36 Lbs/M	Thermocouple Solid	Yes
K14B07	14	0.064	36 Lbs/M	Thermocouple Solid	Yes
K16A09	16	0.051	22 Lbs/M	Thermocouple Solid	Yes
K20A01	20	0.032	15 Lbs/M	Thermocouple Solid	Yes
K20B01	20	0.032	15 Lbs/M	Thermocouple Solid	Yes
K20A04	20	0.032	9 Lbs/M	Thermocouple Solid	Yes
K20B04	20	0.032	9 Lbs/M	Thermocouple Solid	Yes
K20A05	20	0.032	9 Lbs/M	Thermocouple Solid	Yes
K20B05	20	0.032	9 Lbs/M	Thermocouple Solid	Yes
K20A08	20	0.032	15 Lbs/M	Thermocouple Solid	Yes
K20B08	20	0.032	15 Lbs/M	Thermocouple Solid	Yes
K20A09	20	0.032	12 Lbs/M	Thermocouple Solid	Yes
K20B09	20	0.032	12 Lbs/M	Thermocouple Solid	Yes

Standard Construction - Thermocouple Grade

PART NUMBER	B & S WIRE GAUGE	CONDUCTOR DIAMETER	LBS. PER 1000 FT.	T/C OR EXT. GRADE/ CONDUCTOR TYPE	OVERBRAID AVAILABLE
K20A10	20	0.032"	10 Lbs/M	Thermocouple Solid	Yes
K20B10	20	0.032	10 Lbs/M	Thermocouple Solid	Yes
K20A12	20	0.032	13 Lbs/M	Thermocouple Solid	Yes
K20B12	20	0.032	13 Lbs/M	Thermocouple Solid	Yes
K20A13	20	0.032	16 Lbs/M	Thermocouple Solid	Yes
K20B13	20	0.032	16 Lbs/M	Thermocouple Solid	Yes
K20A17	20	0.032	12 Lbs/M	Thermocouple Solid	Yes
K20B17	20	0.032	12 Lbs/M	Thermocouple Solid	Yes
K20A18	20	0.032	11 Lbs/M	Thermocouple Solid	Yes
K20B18	20	0.032	11 Lbs/M	Thermocouple Solid	Yes
K20A19	20	0.032	18 Lbs/M	Thermocouple Solid	Yes
K20B19	20	0.032	18 Lbs/M	Thermocouple Solid	Yes
K20A22	20	0.032	12 Lbs/M	Thermocouple Solid	Yes
K20A23	20	0.032	12 Lbs/M	Thermocouple Solid	Yes
K20B21	20	0.032	8 Lbs/M	Thermocouple Solid	Yes
K20C02	20 (7/28)	0.039	10 Lbs/M	Thermocouple Stranded	Yes
K20B02	20 (7/28)	0.039	10 Lbs/M	Thermocouple Stranded	Yes
K20C17	20 (7/28)	0.039	10 Lbs/M	Thermocouple Stranded	Yes
N20A04	20	0.032	9 Lbs/M	Thermocouple Solid	Yes
N20B01	20	0.032	15 Lbs/M	Thermocouple Solid	Yes
T20A04	20	0.032	9 Lbs/M	Thermocouple Solid	Yes
T20B04	20	0.032	9 Lbs/M	Thermocouple Solid	Yes
T20A05	20	0.032	9 Lbs/M	Thermocouple Solid	Yes
T20B05	20	0.032	9 Lbs/M	Thermocouple Solid	Yes
T20A17	20	0.032	12 Lbs/M	Thermocouple Solid	Yes
T20B17	20	0.032	12 Lbs/M	Thermocouple Solid	Yes
T20A18	20	0.032	11 Lbs/M	Thermocouple Solid	Yes
T20A18	20	0.032	11 Lbs/M	Thermocouple Solid	Yes
T20A19	20	0.038	18 Lbs/M	Thermocouple Solid	Yes
T20B19	20	0.038	18 Lbs/M	Thermocouple Solid	Yes
T20A22	20	0.032	23 Lbs/M	Thermocouple Solid	Yes
T20A23	20	0.032	18 Lbs/M	Thermocouple Solid	Yes
T20B21	20	0.032	10 Lbs/M	Thermocouple Solid	Yes

**14, 16 and 20 gauge wire cataloged. Some insulations also available in 24, 30, and 36 gauge sizes. Consult TMS for availability on these sizes.

WIRE

TMS

Standard Construction - Extension Grade

PART NUMBER	B & S WIRE GAUGE	CONDUCTOR DIAMETER	LBS. PER 1000 FT.	T/C OR EXT. GRADE/ CONDUCTOR TYPE	OVERBRAID AVAILABLE
B20E04	20	0.032	9 Lbs/M	Extension Solid	Yes
C24E17	24	0.020	8 Lbs/M	Extension Solid	Yes
E16E14	16	0.051	28 Lbs/M	Extension Solid	Yes
E16E19	16	0.051	33 Lbs/M	Extension Solid	Yes
E16E20	16	0.051	39 Lbs/M	Extension Solid	Yes
E20E14	20	0.032	14 Lbs/M	Extension Solid	Yes
E20E20	20	0.032	22 Lbs/M	Extension Solid	Yes
J14E14	14	0.064	44 Lbs/M	Extension Solid	Yes
J14F14	14	0.064	44 Lbs/M	Extension Solid	Yes
J16E03	16	0.051	22 Lbs/M	Extension Solid	Yes
J16E14	16	0.051	28 Lbs/M	Extension Solid	Yes
J16F14	16	0.051	28 Lbs/M	Extension Solid	Yes
J16E19	16	0.051	33 Lbs/M	Extension Solid	Yes
J16E20	16	0.051	39 Lbs/M	Extension Solid	Yes
J20E14	20	0.032	14 Lbs/M	Extension Solid	Yes
J20F14	20	0.032	14Lbs/M	Extension Solid	Yes
J20E17	20	0.032	12 Lbs/M	Extension Solid	Yes
J20E20	20	0.032	22 Lbs/M	Extension Solid	Yes
J20F20	20	0.032	22 Lbs/M	Extension Solid	Yes
J20G14	20 (7/28)	0.038	16 Lbs/M	Extension Stranded	Yes
J20H14	20 (7/28)	0.038	16 Lbs/M	Extension Stranded	Yes
J20G20	20	0.032	24 Lbs/M	Extension Solid	Yes
K14E14	14	0.064	44 Lbs/M	Extension Solid	Yes
K16E03	16	0.051	22 Lbs/M	Extension Solid	Yes
K16E14	16	0.051	28 Lbs/M	Extension Solid	Yes
K16F14	16	0.051	28 Lbs/M	Extension Solid	Yes
K16E19	16	0.051	33 Lbs/M	Extension Solid	Yes
K16E20	16	0.051	39 Lbs/M	Extension Solid	Yes
K20E14	20	0.032	14 Lbs/M	Extension Solid	Yes
K20F14	20	0.032	14 Lbs/M	Extension Solid	Yes
K20E17	20	0.032	12 Lbs/M	Extension Solid	Yes
K20E20	20	0.032	22 Lbs/M	Extension Solid	Yes
K20F20	20	0.032	22 Lbs/M	Extension Solid	Yes
K20G14	20 (7/28)	0.038	16 Lbs/M	Extension Stranded	Yes
K20H14	20 (7/28)	0.038	16 Lbs/M	Extension Stranded	Yes
K20G20	20 (7/28)	0.038	24 Lbs/M	Extension Stranded	Yes
K20H20	20 (7/28)	0.038	24 Lbs/M	Extension Stranded	Yes
K20E14	20	0.032	14 Lbs/M	Extended Solid	Yes
K20E20	20	0.032	22 Lbs/M	Extended Solid	Yes

Standard Construction - Extension Grade

PART NUMBER	B & S WIRE GAUGE	CONDUCTOR DIAMETER	LBS. PER 1000 FT.	T/C OR EXT. GRADE/ CONDUCTOR TYPE	OVERBRAID AVAILABLE
S16E09*	16	0.051	22 Lbs/M	Extension Solid	Yes
S16E14*	16	0.051	28 Lbs/M	Extension Solid	Yes
S16E17*	16	0.051	28 Lbs/M	Extension Solid	Yes
S16E20*	16	0.051	39 Lbs/M	Extension Solid	Yes
S20E04*	20	0.032	9 Lbs/M	Extension Solid	Yes
S20E14*	20	0.032	14 Lbs/M	Extension Solid	Yes
S20E17*	20	0.032	12 Lbs/M	Extension Solid	Yes
S20E20*	20	0.032	22 Lbs/M	Extension Solid	Yes
S24E04*	24	0.020	44 Lbs/M	Extension Solid	Yes
T16E14	16	0.051	28 Lbs/M	Extension Solid	Yes
T16F14	16	0.051	28 Lbs/M	Extension Solid	Yes
T16E19	16	0.051	33 Lbs/M	Extension Solid	Yes
T16E20	16	0.051	39 Lbs/M	Extension Solid	Yes
T26E14	20	0.032	14 Lbs/M	Extension Solid	Yes
T20F14	20	0.032	14 Lbs/M	Extension Solid	Yes
T20E20	20	0.032	22 Lbs/M	Extension Solid	Yes
T20F20	20	0.032	22 Lbs/M	Extension Solid	Yes
T20G14	20 (7/28)	0.038	16 Lbs/M	Extension Solid	Yes
T20H14	20 (7/28)	0.038	16 Lbs/M	Extension Solid	Yes

*Extension wire for ANSI Type B, R, and S Thermocouples

Standard Construction - Multipair Cable

PART NUMBER	B & S WIRE GAUGE	APPROXIMATE DIAMETER	LBS. PER 1000 FT.	CONDUCTOR DESCRIPTION AND NUMBER OF PAIRS	ANSI COLOR CODES
J20E402 +	20	0.290	72 Lbs/M	Solid - 2 Twisted	Yes - Black Jacket
J20E404 +	20	0.350	94 Lbs/M	Solid - 4 Twisted	Yes - Black Jacket
J20E408 +	20	0.440	140 Lbs/M	Solid - 8 Twisted	Yes - Black Jacket
J20E4012 +	20	0.535	188 Lbs/M	Solid - 12 Twisted	Yes - Black Jacket
J20E4016 +	20	0.610	240 Lbs/M	Solid - 16 Twisted	Yes - Black Jacket
J20E4020 +	20	0.650	292 Lbs/M	Solid - 20 Twisted	Yes - Black Jacket
J20E4024 +	20	0.710	344 Lbs/M	Solid - 24 Twisted	Yes - Black Jacket
J20E4102 +	20	0.305	77 Lbs/M	Solid - 2 Twisted/Shielded	Yes - Black Jacket
J20E4104 +	20	0.385	104 Lbs/M	Solid - 4 Twisted/Shielded	Yes - Black Jacket
J20E4108 +	20	0.490	160 Lbs/M	Solid - 8 Twisted/Shielded	Yes - Black Jacket
J20E4112 +	20	0.610	218 Lbs/M	Solid - 12 Twisted/Shielded	Yes - Black Jacket
J20E4116 +	20	0.640	280 Lbs/M	Solid - 16 Twisted/Shielded	Yes - Black Jacket
J20E4120 +	20	0.710	342 Lbs/M	Solid - 20 Twisted/Shielded	Yes - Black Jacket
J20E4124 +	20	0.805	404 Lbs/M	Solid - 24 Twisted/Shielded	Yes - Black Jacket

+Available In Special Tolerance.

WIRE



Standard Construction - Multipair Cable

PART NUMBER	B & S WIRE GAUGE	APPROXIMATE DIAMETER	LBS. PER 1000 FT.	CONDUCTOR DESCRIPTION AND NUMBER OF PAIRS	ANSI COLOR CODES
K20E402 +	20	0.290	72 Lbs/M	Solid - 2 Twisted	Yes - Yellow Jacket
K20E404 +	20	0.350	94 Lbs/M	Solid - 4 Twisted	Yes - Yellow Jacket
K20E408 +	20	0.440	140 Lbs/M	Solid - 8 Twisted	Yes - Yellow Jacket
K20E4012 +	20	0.535	188 Lbs/M	Solid - 12 Twisted	Yes - Yellow Jacket
K20E4016 +	20	0.610	240 Lbs/M	Solid - 16 Twisted	Yes - Yellow Jacket
K20E4020 +	20	0.650	292 Lbs/M	Solid - 20 Twisted	Yes - Yellow Jacket
K20E4024 +	20	0.710	344 Lbs/M	Solid - 24 Twisted	Yes - Yellow Jacket
K20E412 +	20	0.305	77 Lbs/M	Solid - 2 Twisted/Shielded	Yes - Yellow Jacket
K20E414 +	20	0.385	104 Lbs/M	Solid - 4 Twisted/Shielded	Yes - Yellow Jacket
K20E418 +	20	0.490	160 Lbs/M	Solid - 8 Twisted/Shielded	Yes - Yellow Jacket
K20E4112 +	20	0.610	218 Lbs/M	Solid - 12 Twisted/Shielded	Yes - Yellow Jacket
K20E4116 +	20	0.640	280 Lbs/M	Solid - 16 Twisted/Shielded	Yes - Yellow Jacket
K20E4120 +	20	0.710	342 Lbs/M	Solid - 20 Twisted/Shielded	Yes - Yellow Jacket
K20E4124 +	20	0.805	404 Lbs/M	Solid - 24 Twisted/Shielded	Yes - Yellow Jacket
T20E404	20	0.350	82 Lbs/M	Solid - 4 Twisted	Yes - Blue Jacket
T20E408	20	0.440	140 Lbs/M	Solid - 8 Twisted	Yes - Blue Jacket
T20E4012	20	0.535	188 Lbs/M	Solid - 12 Twisted	Yes - Blue Jacket
T20E4024	20	0.710	344 Lbs/M	Solid - 24 Twisted	Yes - Blue Jacket
T20E414	20	0.385	104 Lbs/M	Solid - 4 Twisted/Shielded	Yes - Blue Jacket
T20E418	20	0.490	160 Lbs/M	Solid - 8 Twisted/Shielded	Yes - Blue Jacket
T20E4112	20	0.610	218 Lbs/M	Solid - 12 Twisted/Shielded	Yes - Blue Jacket
T20E4124	20	0.805	404 Lbs/M	Solid - 24 Twisted/Shielded	Yes - Blue Jacket

RTD Wire Construction Characteristics

CODE	SINGLE CONDUCTOR		DUPLEX CONDUCTOR		TEMPERATURE RATING		NO. OF WIRES	PHYSICAL CHARACTERISTICS			NOTES
	INSULATION	IMPREGNATION	INSULATION	IMPREGNATION	CONTINUOUS	SINGLE READING		ABRASION RESISTANCE	MOISTURE RESISTANCE	CHEMICAL RESISTANCE	
60	TFE	None	TFE	None	392 F	392 F	3, 4	Good	Excellent	Good	Shielded & Jacketed
61	Extruded FEP	None	Glass FEP. Extruded Braid	None	400 F	500 F	2, 3, 4	Excellent	Excellent	Excellent	
62	Glass Braid	Modified Resin	Glass Braid	Modified Resin	900 F	1000 F	2, 3, 4	Fair	Good	Good	
63	TFE	None	N/A		392 F	392 F	1	Good	Excellent	Excellent	Red Single Conductor
64	TFE	None	N/A		392 F	392 F	1	Good	Excellent	Excellent	White Single Conductor
65	TFE	None	TFE	None	392 F	392 F	3, 4	Good	Excellent	Excellent	No Shield
66	Glass Braid	None	N/A	None	900 F	900 F	1	Fair	Good	Good	White w/Red Tracer
67	Glass Braid	None	N/A	None	900 F	900 F	1	Fair	Good	Good	White
68	PFA	None	PFA	None	392 F	392 F	1,2,3,4	Excellent	Excellent	Excellent	Red
69	PFA	None	PFA	None	392 F	392 F	1,2,3,4	Excellent	Excellent	Excellent	White

WIRE



RTD Wire

PART NUMBER	B & S WIRE GAUGE	APPROXIMATE DIAMETER	LBS. PER 1000 FT.	CONDUCTOR DESCRIPTION AND NUMBER OF CONDUCTORS
D24S612	24 (7/28)	0.024	12 Lbs/M	Stranded Silver Plated Copper - 2 Conductor
D22S612	22 (7/28)	0.030	14 Lbs/M	Stranded Silver Plated Copper - 2 Conductor
D20S612	20 (7/28)	0.038	17 Lbs/M	Stranded Silver Plated Copper - 2 Conductor
D24S613	24 (7/28)	0.024	16 Lbs/M	Stranded Silver Plated Copper - 3 Conductor
D22S613	22 (7/28)	0.030	20 Lbs/M	Stranded Silver Plated Copper - 3 Conductor
D22S613	20 (7/28)	0.038	17 Lbs/M	Stranded Silver Plated Copper - 3 Conductor
D24S614	24 (7/28)	0.024	19 Lbs/M	Stranded Silver Plated Copper - 4 Conductor
D22S614	22 (7/28)	0.030	23 Lbs/M	Stranded Silver Plated Copper - 4 Conductor
D20S614	20 (7/28)	0.038	27 Lbs/M	Stranded Silver Plated Copper - 4 Conductor
D24S603	24 (7/28)	0.024	20 Lbs/M	Stranded Silver Plated Copper - 3 Conductor
D24S622	24 (7/28)	0.024	6 Lbs/M	Stranded Silver Plated Copper - 2 Conductor
D22S622	22 (7/28)	0.030	7 Lbs/M	Stranded Silver Plated Copper - 2 Conductor
D20S622	20 (7/28)	0.038	9 Lbs/M	Stranded Silver Plated Copper - 2 Conductor
D24S623	20 (7/28)	0.024	8 Lbs/M	Stranded Silver Plated Copper - 3 Conductor
D20S623	20 (7/28)	0.038	12 Lbs/M	Stranded Silver Plated Copper - 3 Conductor
D24S631	24 (19/36)	0.024	4 Lbs/M	Stranded Silver Plated Copper - 1 Conductor
D24S641	24 (19/36)	0.024	4 Lbs/M	Stranded Silver Plated Copper - 1 Conductor

RTD Wire Ordering Information:

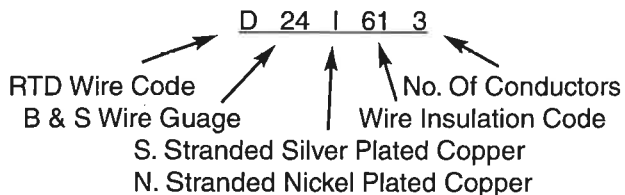

SECTION 6

FITTINGS & HARDWARE

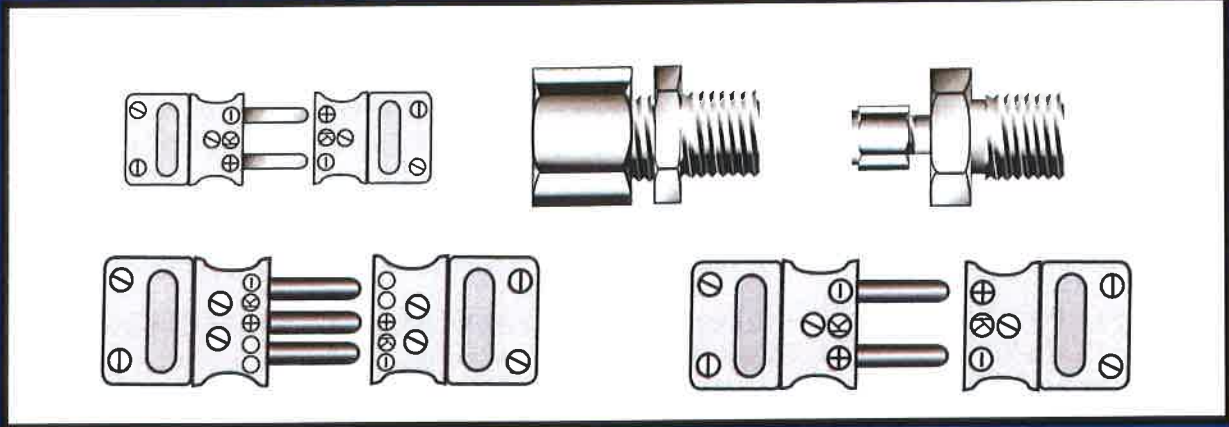

FITTINGS & HARDWARE INDEX-SECTION 6

Compression Fittings – Carbon Steel and Stainless Steel	1
Cord Grip Connectors	1
Thermocouple Connectors – Standard and Miniature	2-3

FITTINGS & HARDWARE



Compression Fittings

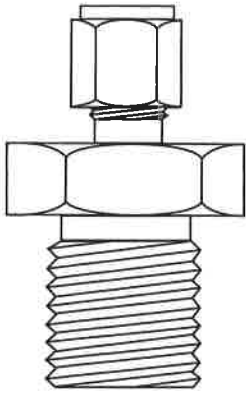

BRASS	CARBON STEEL	STAINLESS STEEL	DESCRIPTION
BA11	CA11	SA11	1/8" NPT X 1/16" TUBE DIA
BA12	CA12	SA12	1/8" NPT X 1/8" TUBE DIA
BA13	CA13	SA13	1/8" NPT X 3/16" TUBE DIA
BA14	CA14	SA14	1/8" NPT X 1/4" TUBE DIA
BA21	CA21	SA21	1/4" NPT X 1/16" TUBE DIA
BA22	CA22	SA22	1/4" NPT X 1/8" TUBE DIA
BA23	CA23	SA23	1/4" NPT X 3/16" TUBE DIA
BA24	CA24	SA24	1/4" NPT X 1/4" TUBE DIA
BA25	CA25	SA25	1/4" NPT X 5/16" TUBE DIA
BA26	CA26	SA26	1/4" NPT X 3/8" TUBE DIA
BA42	CA42	SA42	1/2" NPT X 1/8" TUBE DIA
BA43	CA43	SA43	1/2" NPT X 3/16" TUBE DIA
BA44	CA44	SA44	1/2" NPT X 1/4" TUBE DIA
BA45	CA45	SA45	1/2" NPT X 5/16" TUBE DIA
BA46	CA46	SA46	1/2" NPT X 3/8" TUBE DIA
BA48	CA48	SA48	1/2" NPT X 1/2" TUBE DIA

**Standard fittings are supplied with metallic ferrules Teflon ferrules are. To specify Teflon ferrule add letter designation "T" to basic part number.
Fittings are available in other materials. Consult TMS for availability.

Cord Grip Connectors

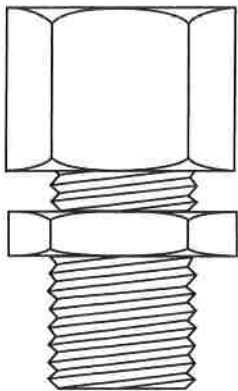

PART NO	CABLE/WIRE DIA.	THREAD SIZE
G3	.125 TO .250	1/2" NPT
G4	.250 TO .375	1/2" NPT
G5	.125 TO .250	3/4" NPT
G6	.250 TO .375	3/4" NPT

FITTINGS & HARDWARE

TMS

CONNECTORS

STANDARD AND MINIATURE CONNECTORS - Standard connectors are available in thermocouple calibrations as well as uncompensated (copper) alloys. These connectors are ANSI color coded and are rated to 350 Deg. F. (400 Deg. F max.). Plugs are available in solid pin and hollow pin constructions.

HIGH TEMPERATURE CONNECTORS - High temperature connectors are available in thermocouple calibrations as well as uncompensated (copper) alloys. These connectors are ANSI color coded and are rated to 500 Deg. F. (550 Deg. F. max.) Ultra High Temperature connectors are also available but are not shown. Ultra High Temperature connectors are rated 800 Deg. F. continuous service or 1000 Deg. F. for intermittent service. Consult TMS for Ultra High Temperature Connectors.

Standard Connectors

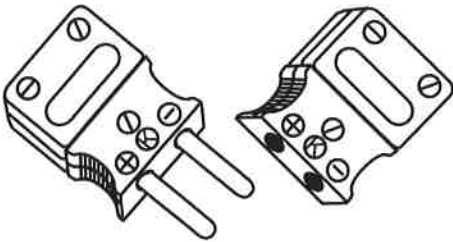

SOLID PIN PLUG	HOLLOW PIN PLUG	JACK	ANSI COLOR CODE	ANSI CALIBRATION
MP1J	MP4J	FJ1J	ORANGE	J
MP1K	MP4K	FJ1K	YELLOW	K
MP1T	MP4T	FJ1T	BLUE	T
MP1R	MP4R	FJ1R	GREEN	R OR S
MP1E	MP4E	FJ1E	PURPLE	E
MP1N	MP4N	FJ1N	ORANGE	N
MP1U	MP4U	FJ1U	WHITE	U

High Temperature Connectors

SOLID PIN PLUG	HOLLOW PIN PLUG	JACK	ANSI COLOR CODE	ANSI CALIBRATION
MP3J	MP4J	FJ2J	HIGH TEMPERATURE CONNECTORS ARE AVAILABLE IN BROWN ONLY.	J
MP3K	MP4K	FJ2K		K
MP3T	MP4T	FJ2T		T
MP3R	MP4R	FJ2R		R OR S
MP3E	MP4E	FJ2E		E
MP3N	MP4N	FJ2N		N
MP3U	MP4U	FJ2U		U

FITTINGS & HARDWARE

TMS

Standard 3-Pin Connectors

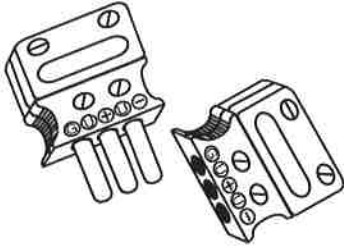

SOLID PIN PLUG	2 HOLLOW 1 SOLID PIN	JACK	ANSI COLOR CODE	ANSI CALIBRATION
MP5J	MP6J	FJ3J	ORANGE	J
MP5K	MP6K	FJ3K	YELLOW	K
MP5T	MP6T	FJ3T	BLUE	T
MP5R	MP6R	FJ3R	GREEN	R OR S
MP5E	MP6E	FJ3E	PURPLE	E
MP5N	MP6N	FJ3N	ORANGE	N
MP5U	MP6U	FJ3U	WHITE	U

Miniature 2-Pin Connectors

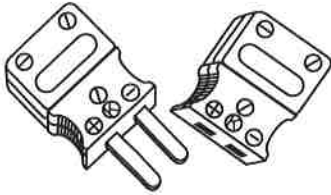

2 PIN PLUG	2 PIN JACK	HIGH TEMP 2 PIN PLUG	HIGH TEMP 2 PIN JACK	ANSI COLOR CODE	ANSI CALIBRATION
MP7J	FJ4J	MP8J	FJ5J	ORANGE	J
MP7K	FJ4K	MP8K	FJ5K	YELLOW	K
MP7T	FJ4T	MP8T	FJ5T	BLUE	T
MP7R	FJ4R	MP8R	FJ5R	GREEN	R OR S
MP7E	FJ4E	MP8E	FJ5E	PURPLE	E
MP7N	FJ4N	MP8N	FJ5N	ORANGE	N
MP7U	FJ4U	MP8U	FJ5U	WHITE	U

Miniature 3-Pin Connectors

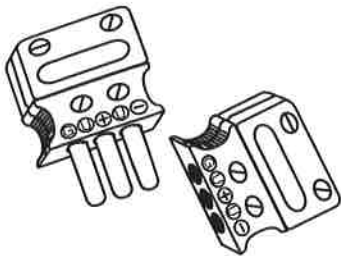

3 PIN PLUG	2 PIN JACK	HIGH TEMP 3 PIN PLUG	HIGH TEMP 3 PIN JACK	ANSI COLOR CODE	ANSI CALIBRATION
MP9J	FJ6J	MP10J	FJ7J	ORANGE	J
MP9K	FJ6K	MP10K	FJ7K	YELLOW	K
MP9T	FJ6T	MP10T	FJ7T	BLUE	T
MP9R	FJ6R	MP10R	FJ7R	GREEN	R OR S
MP9E	FJ6E	MP10E	FJ7E	PURPLE	E
MP9N	FJ6N	MP10N	FJ7N	ORANGE	N
MP9U	FJ6U	MP10U	FJ7U	WHITE	U

NOTES



NOTES



